

# Introduction



It's illegal for commercial drivers to have more than one license. You must keep the license issued by the state where you live. All other licenses must be returned to the states that issued them. If you fail to return licenses from other states, you could be fined up to \$5,000, put in jail for up to 90 days, or both.

You may not hold both a Virginia-issued CDL and a Virginia DMV-issued photo ID.

## CDL Age Requirements

You must be at least 18 years of age to hold a CDL. Under federal law, you must be a commercial driver at least 21 years of age to drive across state lines, transport hazardous materials or transport interstate freight (e.g., mail) within the state. If you are under 21 years of age, you may be issued a CDL with a "L" restriction. This restriction indicates that your driving privileges are valid only in Virginia.

## CDL Instruction Permit

If you want to learn to drive commercial motor vehicles, you must get a commercial driver's license instruction permit. To obtain a CDL instruction permit, you must pass the CDL general knowledge exam and the other knowledge exams for the vehicles that you want to drive. For example, if you want to learn to operate a tank vehicle and a passenger bus, you must take the general knowledge exam, the tank vehicle exam and the passenger vehicle exam. If you intend to drive a vehicle equipped with air brakes, you must take the air brakes exam. If you want to learn to drive a school bus, you must take the general knowledge, school bus and passenger vehicle exams.

The CDL instruction permit allows you to drive a commercial vehicle of the class and type shown on the permit **only** when a person licensed to drive the same type of vehicle is with you. Refer to the Virginia Driver's Manual for an explanation of all requirements including the passenger vehicle general knowledge and road skills tests. When applying for a CDL instruction permit, you must certify on the application that you are or are not required to comply with federal or state regulations.

If you hold a CDL instruction permit, you must hold it for a minimum of 30 days or show proof that you previously held a CDL or that you have completed an approved Virginia CDL driver education course. Additionally, if you received the instruction permit in a state that does not administer a knowledge exam before issuing the instruction permit, you must pass the Virginia General Knowledge CDL exam plus all other applicable exams before a Virginia CDL will be issued to you.

## CDL Classifications

You should get your CDL for the class vehicle you plan to drive plus you may need additional endorsements.

## What is a Commercial Motor Vehicle?

- ▶ a single vehicle with a gross vehicle weight rating (GVWR) of 26,001 pounds or more
- ▶ a combination of vehicles with a gross combination weight rating (GCWR) of 26,001 pounds or more if the vehicle(s) being towed has a GVWR of more than 10,000 pounds
- ▶ vehicles designed to carry 16 or more passengers, including the driver
- ▶ any size vehicle that transports hazardous materials and that requires federal placarding

## Who are Commercial Drivers?

Commercial drivers are all persons, paid or volunteer, who operate commercial motor vehicles. Volunteer drivers of church buses, private or public school buses and mechanics who test drive commercial vehicles must meet commercial driver's license requirements.

Commercial driver's license requirements **don't** apply to:

- ▶ operators of emergency vehicles, such as firefighters
- ▶ active duty military personnel operating military vehicles
- ▶ operators of farm vehicles when
  - ▶ used by farmers
  - ▶ used to move farm goods, supplies or machinery to or from their farm
  - ▶ not used as a common or contract motor carrier, and
  - ▶ used within 150 miles of the farm
- ▶ vehicles operated by persons only for personal use, such as recreational vehicles and rental moving vans.

## Introduction

**Class A** Any combination of vehicles with a gross combination weight rating of 26,001 pounds or more if the vehicle(s) being towed have a GVWR of more than 10,000 pounds. Vehicles in this class include:

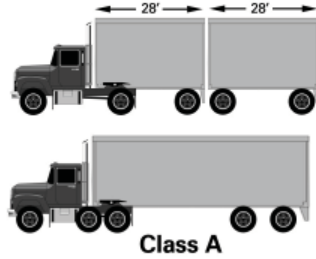

- ▶ tractor-trailer
- ▶ truck and trailer combinations
- ▶ tractor-trailer buses

If you hold a class A license and you have the correct endorsements, you may also operate vehicles listed in classes B and C.

**Class B** Any single vehicle with a GVWR of 26,001 pounds or more. Any single vehicle with a GVWR of 26,001 pounds or more towing another vehicle with a GVWR of 10,000 pounds or less.

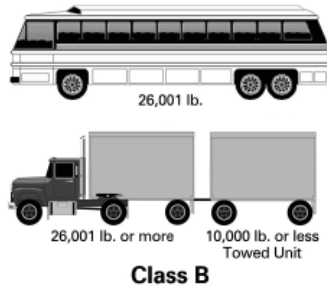

This class includes:

- ▶ straight trucks
- ▶ large buses
- ▶ segmented buses
- ▶ trucks towing vehicles with a GVWR of 10,000 pounds or less

If you hold a class B license and you have the correct endorsements, you may also operate vehicles listed in class C.

**Class C** Any vehicle that is not included in classes A or B that carries hazardous materials requiring placards or is designed to carry 16 or more passengers, including the driver.



Remember, the class of a vehicle is determined by its gross vehicle weight rating and the manufacturer's design. The vehicle's class determines the type of CDL and endorsements that you need. If you drive a redesigned or altered vehicle, the vehicle's original class determines the type of CDL and endorsements that you need. The type of CDL that you need is not determined by the class that the redesigned vehicle falls within.

## CDL Endorsements

- H** Permits you to drive a vehicle that transports hazardous materials.
- N** Permits you to drive a tank vehicle.
- P** Permits you to drive a passenger-carrying vehicle.
- S** Permits you to drive a school bus.
- T** Permits you to drive a double or triple trailer.

## CDL Restrictions

- J** You may only operate a school/activity bus. You may not operate any other type of commercial motor vehicle.
- K** You may not operate a vehicle with air brakes. If you plan to operate a vehicle with air brakes, you must take the air brakes knowledge exam. You must also take the road test in a vehicle equipped with air brakes.
- L** You may not operate a commercial motor vehicle outside of Virginia.
- M** Operation of a passenger bus restricted to a Class B passenger vehicle.
- N** Operation of a passenger bus restricted to a Class C passenger vehicle.
- Y** You must wear corrective lenses when operating a commercial motor vehicle.

## Moving Violations

If you receive an intrastate CDL when you are under age 20 and you renew at age 20, you must retake all exams if you have received one or more moving violations.

## CDL Fees

Commercial driver's licenses issued by DMV are valid for eight years. CDL holders with a hazardous materials endorsement must continue to follow the federal guidelines and renew their hazmat endorsement every five years. The validity period for driver's licenses issued to persons registered as sex offenders will be no more than five years.

	Original	Renewal	Replacement
Driver's License	\$4.00 per year	\$4.00 per year	\$10.00
CDL designation	\$3.00 per year	\$3.00 per year	\$10.00
Class	\$1.00 per year	\$1.00 per year	N/C
Endorsements*	\$1.00 per year	\$1.00 per year	N/C
CDL instruction permit	\$3.00		\$2.00

The CDL fee is \$8.00 per year. This includes the \$4.00 driver's license fee, the \$3.00 CDL designation, plus \$1.00 for the CDL class. Since the CDL validity period is eight years, your fee will be \$64.

\*Endorsements are \$1 per year regardless of the number of endorsements you receive.

Federal law requires applicants for hazardous materials endorsements to be fingerprinted for a background check. The background check fee is \$83.00.

## Getting Your CDL

To obtain your CDL, you must meet the requirements for a Virginia driver's license including the following:

### Proof of Identity, Legal Presence, Virginia Residency and Social Security Number

If you do not hold a valid Virginia driver's license, you must present the following documents.

- ▶ **2 proof of identity documents**, such as a driver's license, birth certificate, Virginia CDL instruction permit, unexpired U.S. military identification card or U.S. military discharge papers. You must provide original or duplicate documents. Photocopies will not be accepted. Refer to *Acceptable Documents for Obtaining a Driver's License or Photo ID card* (DMV 141) for a complete list of acceptable documents.
- ▶ **1 proof of legal presence** such as a U.S. birth certificate or U.S. passport. Legal presence can be proved using a variety of other documents, such as a Certificate of Citizenship or naturalization, Resident Alien Card, or a valid foreign passport with a visa, I-94 or an I-94W with a participating country. Later in 2004, if you apply for a hazardous materials endorsement, you will be required to provide specific documents to meet federal requirements.
- ▶ **1 proof of Virginia residency** and the street address of your principal Virginia residence. If you are under age 19, your parent or guardian must certify your Virginia residency. All documents must show your name and the address of your principal Virginia residence as it appears on your application. A post office box or business address is not acceptable.  
  
However, if you do not want your residence address to appear on your CDL, you may provide DMV with an alternate address in addition to your residence address. This alternate address must also be in Virginia. If you change your residence or alternate address to a location outside Virginia, your CDL will be cancelled. Exceptions may be made for some individuals such as active duty military personnel and Virginia residents employed outside the U.S. Refer to *Acceptable Documents for Obtaining a Driver's License or Photo ID card* (DMV 141) for more information.
- ▶ **1 proof of your social security number**, such as your social security card, IRS W-2 form, payroll check or check stub, unexpired U.S. military identification card or income tax return from a previous year. DMV will assign you a customer number which will display on your CDL or CDL instruction permit.

### Selective Service Registration

Generally, males under age 26 must register with the Selective Service. If you are required by federal law to register with the Selective Service, you must authorize DMV to send your personal information to Selective Service unless you have already

registered. If you are underage 18, your parent or guardian must sign your application authorizing the Selective Service to register you when you turn 18. Law prohibits DMV from issuing any type of driver's license or photo ID card to an applicant who is required by federal law to register with the Selective Service but who refuses to authorize DMV to send his information to Selective Service. If you have questions about Selective Service registration, visit the Selective Service web site at [www.sss.gov](http://www.sss.gov) or call 847-688-6888, TTY: 847-688-2567.

### Out-of-State CDL

If you hold an expired out-of-state CDL, you must pass all required CDL knowledge and skills tests to qualify for a Virginia CDL. Virginia does not recognize tests or certificates from out-of-state third party testers or driving schools.

### Compliance with Motor Carrier Safety Regulations

All CDL applicants must certify that they are in compliance with the federal and Virginia motor carrier safety regulations.

Virginia law requires that, beginning January 30, 2012, all CDL applicants who certify that they will operate a commercial motor vehicle in non-excepted interstate or intrastate commerce shall provide the Department of Motor Vehicles with an original or certified copy of a medical examiner's certificate prepared by a medical examiner as defined by the Federal Motor Carrier Safety Administration. Any commercial driver who fails to comply with these requirements will not be eligible for a commercial driver's license.

To obtain a medical examination form, contact J. J. Keller and Associates at 1-800-327-6868, Label Master at 1-800-621-5808, the Virginia Trucking Association or the Federal Motor Carrier Safety Administration at [www.fmcsa.dot.gov](http://www.fmcsa.dot.gov). Vendors may charge a fee for this form.

### Vision Standards

To operate commercial motor vehicles, you must have:

- ▶ 20/40 or better vision in each eye with or without corrective lenses, and
- ▶ 140 degrees or better horizontal vision.

These visual requirements must be met without the aid of a telescopic lens. Additionally, you must be able to recognize traffic signs and devices showing standard red, green or amber indicators. Some drivers may be granted waivers from these vision requirements. For information concerning waivers for intrastate travel, contact DMV. For information concerning waivers for interstate travel, contact the Federal Motor Carrier Safety Administration at Vision Program, 400 7th Street, S.W., Washington, DC 20590.

Motor carriers are required to comply with a variety of federal and state laws that are not addressed in this manual. Learn about the requirements in the Motor Carrier Programs section of the DMV website, [www.dmvNOW.com](http://www.dmvNOW.com).

## Taking the CDL Tests

All commercial vehicle drivers (class A, B and C vehicles) must take the general knowledge exam. Check the following chart to find out which exams you need to take in addition to the general knowledge exam.

To drive this vehicle:	Study this section:
Class A, B and C	Section 1: General Knowledge Section 6: Transporting Cargo
Vehicles with air brakes	Section 2: Air Brakes <i>If you do not take the air brakes exam, you will be restricted to driving vehicles without air brakes (K restriction)</i>
Class A combination vehicle	Section 3: Combination Vehicles
<b><i>In addition to the exams listed above, you must take special exams for each endorsement:</i></b>	
T – Double-triple trailer	Section 4: Doubles and Triples
H – Hazardous materials	Section 9: Hazardous Materials <i>The hazardous materials endorsement test cannot be taken using a translator. This test cannot be administered orally.</i>
N – Tank vehicle	Section 7: Tank Vehicles
P – Passenger vehicle	Section 8: Transporting Passengers
S – School bus	Section 5: School Buses

### Be Prepared

- ▶ You may take the CDL knowledge exam(s) only once per business day. If you fail any knowledge exam, you must pay a \$2 re-examination fee if you retake the exam within 15 days.
- ▶ If you fail the commercial driver's license general knowledge exam three times, you will not be permitted to take it a fourth time until you successfully complete the knowledge component of driver instruction at a driver training school approved by DMV. You must complete the driver instruction after the third unsuccessful attempt to pass the test. Upon completion of the knowledge component and presentation of your certificate of completion, DMV will allow you to take the knowledge test again.
- ▶ If you fail the commercial driver's license behind-the-wheel test three times, you will not be permitted to take it a fourth time until you successfully complete the in-vehicle component of driver instruction at a driver training school approved by DMV. You must complete the driver instruction after the third unsuccessful attempt to pass the test. Upon completion of the in-vehicle component and presentation of your certificate of completion, DMV will allow you to take the behind-the-wheel test again.
- ▶ If you fail to show up for a scheduled CDL skills test without notifying the examiner in advance, DMV will charge you a \$50 fee.

### Test Tip

The knowledge exam determines your familiarity with the operation of commercial vehicles, motor vehicle laws and safe driving techniques. Test questions are taken from the information

in this manual. You must answer at least 80 percent of the general knowledge questions correctly. To prepare for the knowledge exam, study **all** information in this manual. When taking the knowledge exam, select the one best answer. Remember, your first answer is usually correct.

Once you pass the required knowledge exam(s), you can take the CDL skills exams. These exams include three areas:

- ▶ Pre-trip inspection
- ▶ Basic vehicle control
- ▶ On-road driving

You must take the skills exams in the type of vehicle for which you want to be licensed. Translators cannot be used during the pre-trip inspection, basic vehicle control, or the road skills test.

## Disqualifications

If you are convicted of any of the following violations when driving a commercial or non commercial motor vehicle, you will be disqualified or prohibited from driving commercial vehicles.

- ▶ You will receive a **one-year** disqualification for the following offenses:
  - ▶ Driving with a blood alcohol content (BAC) of 0.04 percent
  - ▶ Driving while under the influence of drugs
  - ▶ Refusing a blood and/or breath test
  - ▶ Leaving the scene of an accident
  - ▶ Using a vehicle to commit a felony
  - ▶ Driving a commercial motor vehicle (CMV) when, as a result of prior violations committed operating a CMV, the driver's CDL is revoked, suspended, or canceled or the driver is disqualified from operating a CMV
  - ▶ Causing a fatality through the negligent operation of a CMV
  - ▶ Making a false statement on any application for a commercial driver's license
  - ▶ Falsifying a urine test
- ▶ You will receive a **two-year** disqualification if you are convicted of violating an out-of-service order while operating a commercial motor vehicle designated to transport 16 or more passengers, including the driver.
- ▶ You will receive a **three-year** disqualification if you were convicted of one of the offenses listed above while transporting hazardous materials.
- ▶ You will receive a **life-time** disqualification if you: receive a second conviction for one of the violations listed above; or, if you are convicted of using a commercial motor vehicle in the manufacture or illegal distribution of drugs.
- ▶ You will receive a **60-day** disqualification if you are convicted of two serious violations within a three-year period.
- ▶ You will receive a **120-day** disqualification if you are convicted of three or more serious violations within a three-year period.
- ▶ You will receive a **one-year** disqualification for your first conviction of violating of an out-of-service order.

- ▶ You will receive a **two-year** disqualification for your first conviction of violating an out-of-service order while operating a vehicle carrying hazardous materials or designed to carry 16 or more passengers.
- ▶ You will receive a **five-year** disqualification for the second and following convictions of violating out-of-service orders.
- ▶ You will receive a **five-year** disqualification if you are convicted of voluntary or involuntary manslaughter where a death occurred as a direct result of the operation of a commercial vehicle.
- ▶ You may not operate commercial motor vehicles if you are convicted of driving under the influence even if you are issued a restricted license that allows you to drive during the suspension period. This applies even if the violation occurred in your personal car.

If the Federal Motor Carrier Safety Administration (FMCSA) notifies DMV that you have been determined to be an eminent hazard and disqualified from operating a commercial motor vehicle, the information will be noted on your driving record. Also, any disqualification imposed by DMV will run concurrently with the disqualification imposed by FMCSA.

**Serious traffic** violations are:

- ▶ Driving 15 or more miles per hour in excess of the posted speed limit
- ▶ Reckless driving
- ▶ A violation resulting in a fatal traffic crash
- ▶ Improper or erratic traffic lane change
- ▶ Following the vehicle ahead too closely
- ▶ Driving a commercial motor vehicle without a CDL
- ▶ Driving a commercial motor vehicle without a CDL in the driver's immediate possession
- ▶ Driving a commercial motor vehicle without the proper CDL class and/or endorsements for the specific vehicle group being operated or for the passengers or type of cargo being transported
- ▶ Texting while operating a commercial motor vehicle

All CDL drivers are subject to Virginia's controlled substance and alcohol testing laws. If you operate a commercial vehicle under the influence of alcohol or drugs, refuse to take a blood alcohol test or are found to have a BAC of 0.04 percent or greater, your CDL will be disqualified. The disqualification period ranges from one year to life, but does not necessarily affect your privilege to drive a non-commercial vehicle.

If you operate a vehicle on Virginia's roadways, you agree to take a chemical test upon request to determine if you are driving under the influence of alcohol or drugs. This is called implied consent.

Any person who possesses or consumes an alcoholic beverage while operating a school bus transporting children is guilty of a Class 1 misdemeanor. A person convicted of this offense is punishable by confinement in jail for up to 12 months and/or a fine of up to \$2,500.

If the police have probable cause to stop you and suspect that you have been drinking or using drugs, they will ask you to take a breath test. This test analyzes the amount of alcohol and drugs in your body. Under implied consent laws, if you operate a motor vehicle on Virginia's public roads, you agree to take a chemical test upon request.

You are required to take the test. If you refuse, your license will be immediately suspended for seven days and it may be suspended for one year, whether or not you are convicted of driving under the influence. If you are convicted of DUI, the suspension period for refusing the test will be added to the DUI revocation period.

**Railroad crossing violations** will result in a

- ▶ **60-day** disqualification for a first offense
- ▶ **120-day** disqualification for a second offense committed within three years
- ▶ **one-year** disqualification for a third offense committed within three years.

Virginia law prohibits the court from allowing drivers of commercial motor vehicles, or persons holding a CDL and operating a non-commercial motor vehicle, to attend a driver improvement clinic in lieu of a conviction, or to reduce or defer a conviction.

If you are convicted of a felony sexual offense involving a minor, you must register with the Virginia State Police. You must re-register within 30 days of moving.

## Organ/Tissue Donation

When you apply for your driver's license, learner's permit, commercial driver's license or photo ID card, you will be asked if you wish to become an organ donor. If you decide to become a donor, your choice will be noted on the front of your driver's license or photo ID card. If you wish to change your decision later, you must notify DMV and pay a \$10.00 fee. You may also complete this transaction on the Internet with a DMV-issued PIN number. You may have the change made free of charge at your next renewal. The decision to become an organ/tissue donor will not affect your driving privileges.

## Applying to Register to Vote

You can use DMV's driver's license application to indicate your wish to apply to register to vote. You may also use the driver's license application to change your voter registration, name and address. You may also use the separate address change notification form.

You are not registered to vote until your local registrar approves your application. Once registered, you will receive a card showing your voting location and election district. Contact your local registrar if you do not receive this notification.

If you have questions, contact the State Board of Elections, 1-800-552-9745 (TDD 1-800-260-3466).

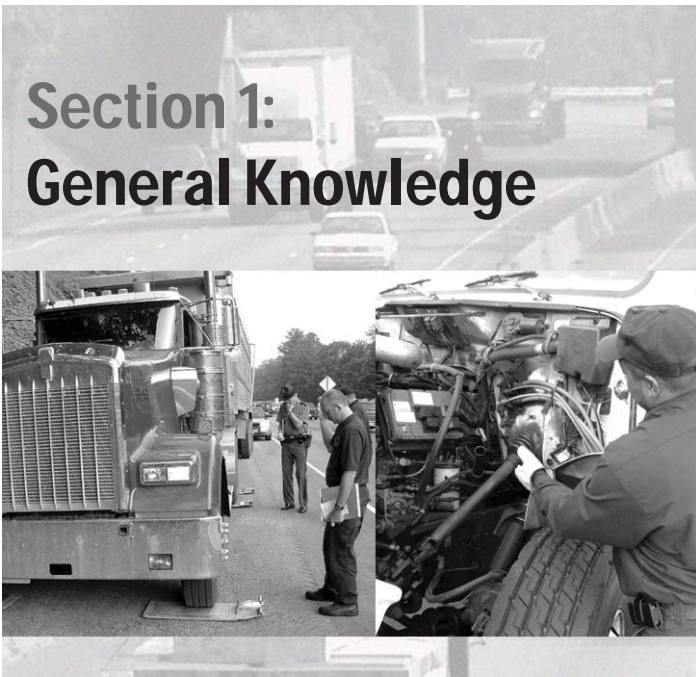

**Safety is** the most important reason to inspect your vehicle. Inspecting your vehicle for defects can prevent breakdowns and crashes.

Federal and state laws require drivers to inspect their vehicles before every trip. Federal and state inspectors can inspect your vehicle. If they find that it is unsafe, they can put it out of service until you have it fixed. If you are convicted of violating an out-of-service order, your CDL will be disqualified.

**There are three kinds of inspections:**

- ▶ pre-trip
- ▶ during the trip
- ▶ after the trip

**Pre-trip Inspection**

A pre-trip inspection helps you find problems that could cause a breakdown or crash.

**What to Look for During the Inspection**

**Tires** (all axles)

- ▶ Check for proper tire pressure using an air pressure gauge.
- ▶ It is illegal to use regrooved, recapped or retreaded tires on the front wheels of a bus.
- ▶ Look for:
  - ▶ Mismatched tire sizes
  - ▶ Radial and bias-ply tires used together
  - ▶ At least 4/32" of tread depth in major grooves on front tires

- ▶ At least 2/32" of tread depth in major grooves on other tires
- ▶ Cuts or other damage
- ▶ Dual tires touching

**Wheels and rims** (all axles)

Check for:

- ▶ Damaged rims or wheels
- ▶ Rust around wheel nuts; loose lug nuts
- ▶ Missing clamps, spacers, studs or lugs
- ▶ Mismatched, bent or cracked lock rings
- ▶ Wheels or rims that have been welded
- ▶ Axle seal/hub oil seal—not leaking; proper fluid level

**Brakes** (all axles)

Look for brake drum and shoe problems on front, rear and trailer brakes:

- ▶ Cracked drums
- ▶ Shoes or pads with oil, grease or brake fluid on them
- ▶ Shoes worn thin, missing or broken
- ▶ Cracked, worn or frayed air hoses
- ▶ Cracks or dents in the air chamber
- ▶ Broken or loose slack adjusters; should not be at more than a 90 degree angle with brakes applied

**Steering system**

Look for:

- ▶ Missing nuts, bolts, cotter keys or other parts on the steering box
- ▶ Bent, loose or broken parts of the steering linkage including the steering gear box, pitman arm and the drag link.
- ▶ Worn or frayed power steering hoses; pumps mounted securely, no leaks; and fluid level full
- ▶ Power steering fluid leaks
- ▶ Steering wheel play of more than 10 degrees (approximately 2 inches of movement at the rim of a 20-inch steering wheel)

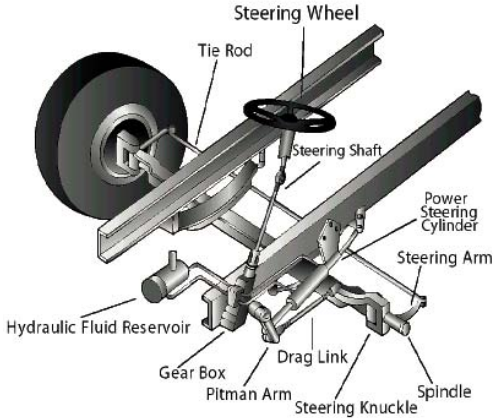

- ▶ If your vehicle has a steering axle brake, be sure that it is never disabled.

**Suspension system** (all axles)

The suspension system holds up the vehicle and its load. It keeps the axles in place. Therefore, broken suspension parts are very dangerous. Look for front, rear and trailer suspension defects:

- ▶ Spring hangers that allow movement of an axle from the proper position
- ▶ Cracked or broken spring hangers
- ▶ Missing or broken leaves in any leaf spring. If one fourth or more are missing, your vehicle could be put out of service. But, any defect is dangerous.
- ▶ Broken leaves in the multileaf spring
- ▶ Leaves that have shifted and could hit a tire or other part
- ▶ Leaking shock absorbers
- ▶ Torque rod or arm, u-bolts, spring hangers or other axle positioning parts that are cracked, damaged or missing
- ▶ Air suspension systems that are damaged and or leaking
- ▶ Any loose, cracked, broken or missing frame members

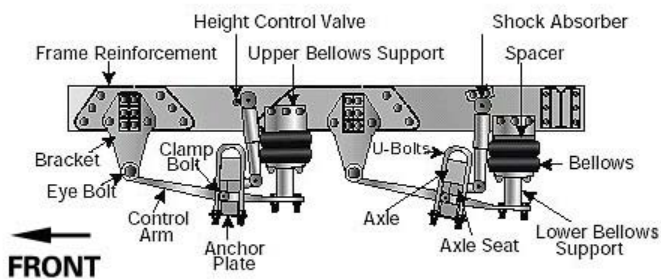
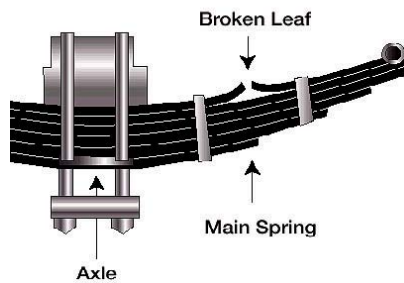
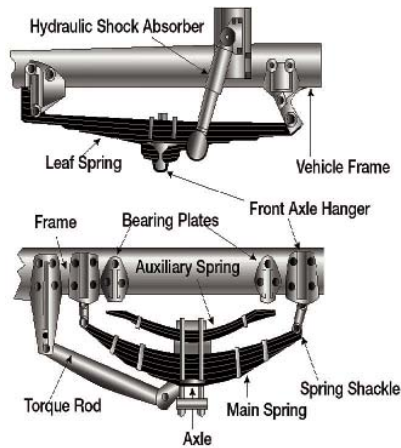

**Exhaust system**

Check for:

- ▶ Leaking parts
- ▶ Leaks which could allow carbon monoxide to leak into your cab

- ▶ Parts rubbing against the fuel system, tires or other moving parts
- ▶ Loose, broken or missing parts

**Emergency equipment**

Your vehicle must be equipped with the following emergency equipment:

- ▶ Properly charged and securely mounted fire extinguisher
- ▶ Spare electrical fuses
- ▶ Three reflective triangles

**Cargo**

- ▶ Make sure your truck is not overloaded. Be sure that the cargo is balanced and secured before each trip.
- ▶ If you are carrying hazardous materials, be sure you have the proper papers and placarding.

**Inspection Steps**

Before you inspect the vehicle, make sure that the parking brakes are on and the wheels are chocked. If you have to tilt the cab, secure loose items so they won't fall.

**Review the last vehicle inspection report.** Drivers may have to make a vehicle inspection report each day. The motor carrier must repair any items that affect safety. The motor carrier must certify on the report that the repairs were made or that they were unnecessary.

**Check the engine compartment.**

- ▶ Engine oil level
- ▶ Coolant level in radiator, condition of hoses
- ▶ Power steering fluid level; hose condition
- ▶ Battery fluid level, connections and tie downs
- ▶ Automatic transmission fluid level (you may have to start the engine)
- ▶ Check belts for tightness and wear (alternator, water pump, air compressor)
- ▶ Leaks in the engine compartment—fuel, coolant, oil, power steering fluid, hydraulic fluid, water pump

**Start the engine and inspect inside the cab.**

- ▶ Check the **gauges** to be sure they are working properly.
  - ▶ Oil pressure should come up to normal within seconds after the engine is started.
  - ▶ Ammeter and/or voltmeter
  - ▶ Coolant temperature
  - ▶ Engine oil temperature
  - ▶ Warning lights and buzzers should go out right away.
- ▶ Check the **controls** for looseness, sticking, damage or improper setting.

## Section 1: General Knowledge

- ▶ Steering wheel
- ▶ Clutch
- ▶ Accelerator
- ▶ Brake controls
- ▶ Foot brake
- ▶ Trailer brake
- ▶ Parking brake
- ▶ Retarder controls
- ▶ Transmission controls
- ▶ Interaxle differential lock
- ▶ Horns
- ▶ Windshield wiper/washer
- ▶ Lights—be sure none are broken and the lenses are clean
  - ▶ Headlights
  - ▶ Dimmer switch
  - ▶ Turn signals
  - ▶ 4-way flashers
  - ▶ Clearance, identification, marker light switches
- ▶ Check the **mirrors and windshield**. Look for cracks, dirt, illegal stickers or other obstructions.
- ▶ Check the **emergency equipment**.
  - ▶ Working fire extinguisher—properly charged and mounted
  - ▶ Spare electrical fuses
  - ▶ Three reflective triangles

**Turn off the engine and check the lights and 4-way flashers.**

**Make a walk-around inspection.**

- ▶ Check that all **lights** are working.
- ▶ Check the **left front side**.
  - ▶ Driver's door glass and side view mirrors—clean, properly mounted and not broken
  - ▶ Door opens and closes properly and fits flush against the cab
  - ▶ Left front wheel
  - ▶ Left front suspension
  - ▶ Left front brake
- ▶ **Front**
  - ▶ Front axle
  - ▶ Steering system
  - ▶ Windshield
  - ▶ Lights and reflectors—not broken, lenses clear and clean

- ▶ **Right side**
  - ▶ Right front—check same items as checked for left front
  - ▶ Fuel tanks—no leaks, bands tight, secure to vehicle, fuel cap tight
  - ▶ Condition of visible parts
    - ▶ Rear of engine
    - ▶ Transmission
    - ▶ Driveshaft—not loose, not bent or broken
    - ▶ Exhaust system—visible parts securely mounted; no cracks, holes or severe dents; air hoses and electrical lines clear of exhaust system
    - ▶ Frame and cross members—not cracked, broken, bent or welded, no signs of breaks or holes in box or trailer floor
    - ▶ Air lines and electrical wiring—secured to prevent snagging, rubbing, wearing
    - ▶ Spare tire carrier or rack
    - ▶ Spare tire and/or wheel securely mounted in rack
    - ▶ Spare tire and wheel (proper size, properly inflated)
- ▶ **Cargo securement (for trucks)**
  - ▶ Cargo properly blocked, braced, tied, chained
  - ▶ Header board adequate and secure
  - ▶ Side boards and stakes strong enough, free of damage and properly set in place.
  - ▶ Canvas or tarp (if required) properly secured to prevent tearing, billowing or blocking of mirrors
  - ▶ If vehicle is oversized, check that all required signs, flags, lamps and reflectors are safely and properly mounted and that you have all required permits.
  - ▶ Check that all curbside cargo compartment doors are securely closed, latched or locked and that required security seals are in place.
- ▶ **Right rear**
  - ▶ Wheels and rims
  - ▶ Tires—rear tire tread depth at least 2/32 of an inch; may be retreads
  - ▶ Lug nuts
  - ▶ Axle seals
  - ▶ Spacers—dual wheels are evenly separated and tires are not touching one another; spacers not bent, damaged or rusted
  - ▶ Suspension
  - ▶ Brakes
  - ▶ Lights and reflectors

- ▶ Spacers (if applicable—not cracked, broken or loose)
- ▶ Axle seal/hub oil seal—not leaking and at proper level
- ▶ **Rear**
  - ▶ Lights and reflectors
  - ▶ License plate
  - ▶ Splash guards
  - ▶ Cargo securement
- ▶ **Left side**—Check all items checked for the right side. Also check:
  - ▶ Battery(s) if they are not mounted in the engine compartment

### Check the signal lights.

### Start the engine and check the brake system.

- ▶ **Hydraulic brake check**
  - ▶ If the vehicle has hydraulic brakes, pump the brake pedal 3 times.
  - ▶ Apply firm pressure to the pedal and hold for 5 seconds.
  - ▶ The pedal should not move.
  - ▶ If it does, there may be a leak or other problem. Get it fixed before driving.
- ▶ **Air brake check**
  - ▶ If the vehicle has air brakes, build air pressure to 100-120 psi. **Turn off the engine, release all brakes.**
  - ▶ Press hard on the foot brake and hold down for one minute.
    - ▶ On combination vehicles, air pressure should not drop over 4 psi.
    - ▶ On single vehicles, air pressure should not drop over 3 psi.
  - ▶ **Turn ignition on**
  - ▶ With the foot brake, pump the air pressure down. At about 60 psi, the low air light must come on. A buzzer may sound as well. On older vehicles, a wig-wag arm will fall in view of the driver.
  - ▶ **Keep pumping air down** with foot brake. At about 40 psi, the parking brake knob and, if applicable, the trailer parking brake knob should pop out.

Failure to perform the air brake check during pre-trip inspection will result in the automatic failure of the CDL road skills exam.

- ▶ **Parking brake check**
  - ▶ Set the parking brake.
  - ▶ Put the vehicle in low gear and gently release the clutch until you feel the vehicle pulling against the brake.
  - ▶ The vehicle should not move.

If you find anything wrong with the brake system, get it fixed before you drive.

- ▶ **If you are driving a bus**, also check:
  - ▶ the passenger entry—steps and handrails secure, no worn matting, door opens and closes correctly
  - ▶ seating—secure
  - ▶ emergency exits—open and close correctly. Check on both outside and inside.
  - ▶ baggage compartment—door opens and closes correctly and is secure.
- ▶ **If you are driving a tractor trailer**, also check:
  - ▶ air/electrical lines—no leaks, cuts, cracks or signs of wear; no tangles or dragging against tractor parts; glad hands secure, or objects securely bolted to tractor frame
  - ▶ catwalk—clear and not loose
  - ▶ all parts of the coupling system (5th wheel lower plate, etc. you will not be able to see the lower plate if the vehicle is hooked up)—loose or missing mounting brackets, clamps, bolts or nuts; 5th wheel and slide mounting securely in place
  - ▶ trailer-front side and rear (air/electrical connections, header board, landing gear, etc.)
  - ▶ safety latch—in position over locking lever
  - ▶ platform—no cracks or breaks in platform structure
  - ▶ release arm—in engaged position and safety latch in place
  - ▶ kingpin/apron—kingpin not bent; apron lays flat on 5th wheel skid plate; visible part of apron is not bent, cracked or broken; locking jaws completely closed around shank or kingpin
  - ▶ sliding 5th wheel locking pins—in the locked position; not broken or damaged
  - ▶ lights and reflectors—not broken, lenses clear and clean

Remember, semi-trailers cannot exceed a length of 53 feet.

## Section 1: General Knowledge

If you find anything unsafe during the pre-trip inspection, get it fixed before you drive. It's against federal and state laws to operate an unsafe vehicle.

### Inspection During the Trip

- ▶ Watch your gauges for signs of trouble.
- ▶ Use your senses to check for problems. Look, listen, smell, and feel.
- ▶ Check critical parts when you stop:
  - ▶ Tires, wheels and rims
  - ▶ Brakes
  - ▶ Lights and reflectors
  - ▶ Brake and electrical connections to the trailer
  - ▶ Trailer coupling devices
  - ▶ Cargo covers and tiedowns

It's a good idea to inspect your vehicle within the first 50 miles of the trip and also every 150 miles or every 3 hours (whichever comes first).

### After-trip Inspection and Report

Inspect your vehicle at the end of the trip, day, or tour of duty. If you find any problems, report them to your employer. Additionally, whether or not you find problems, you must complete a written report and sign it.

Buckle up on every trip. It's the law.

### Test Tips

As part of the CDL road test, you must make a pre-trip inspection of your vehicle. During your pre-trip inspection, you **must**:

- ▶ Point to or touch each essential part of your vehicle.
- ▶ Name the part.
- ▶ Explain what damage or problems you might find with the part.

Your inspection must include the engine compartment, inside cab, front, side, under and rear of the vehicle. When you inspect the cab, you must also perform engine start-up and air brake checks. Failure to perform the air brake check will result in an automatic test failure.

An examiner will grade your inspection. You must receive a passing grade before you continue with the basic vehicle control and on-road exams.

Two backing maneuvers are required as part of the CDL road test. You will be graded on:

- ▶ Using your horns and flashers
- ▶ Checking your mirrors
- ▶ Staying within the path
- ▶ Number of times you attempt the maneuver
- ▶ Cones

## Department of Motor Vehicles

## Vehicle Inspection Study Guide

### TRUCK/TRAILER (PINTLE HOOK)

During the actual tests, you will be expected to point to or touch each of the parts of your vehicle listed below. Name the part and explain what damage or problems you might find. The types of damages or problems are listed below and in the vehicle inspection section in the CDL Manual.

Note: All axles touching the ground on one side of the vehicle must be inspected.

**This study guide cannot be used during the actual pre-trip inspection portion of the skills test.**

#### Front of Vehicle

**Lights** Check for proper color/clean lenses, cracks, missing screws and condensation. Also check for function, left/right turn signals, headlights, high/low beam and four-way flashers.

**Steering Box** Check for missing/loose bolts, cracks and nonfactory welds. Check for steering fluid leaks and torn or frayed hoses.

**Steering Linkage** Check the steering column, pitman arm and drag link for cracks, bends, non-factory welds, missing castle nuts/cotter pins and proper lubrication.

#### Engine Compartment

**Oil Level** Check by pulling out the dipstick, wiping it and reinserting it, then pull out to look at the low and full marks to determine the level.

**Coolant Level** Observe the site glass or line markings for proper level. If not equipped, explain removing radiator cap for level. (**Do not remove cap.**)

**Power Steering Fluid** Observe the sight glass or line markings for proper level. If not equipped, open the cap and check for proper level.

**Water Pump** Check for missing/loose bolts, cracks, proper belt tension, cracked or frayed belts and coolant leaks.

**Alternator** Check for missing/loose bolts, cracks, proper belt tension, cracked or frayed belts, and cracked, burnt or loose wires.

**Air Compressor** Check for missing/loose bolts. Check belts for tension, cracked or frayed lines and leaks.

**Leaks** Look under the engine compartment for coolant, power steering, transmission and oil leaks.

**Hydraulic Brakes (if equipped)** Check the site glass or line on container for proper brake fluid. Check the master cylinder for cracks, leaks, check the brake lines for cracks, frays and brake fluid leaks.

#### Inside the Vehicle

(start engine)

**Clutch/Gearshift** If standard, check for excessive play in clutch—no more than two inches. Check the gear ranges to ensure they engage. Check the boot for holes and dry rot. If automatic, check gearshift for ranges.

**Air Pressure Gauge** Check for cracks and cleanliness. Air pressure should build to a minimum of 100 PSI in both the primary and secondary system.

**Oil Pressure Gauge** Check the gauge for cracks and cleanliness. Oil pressure should come up to normal within seconds after the engine is started. If no gauge, identify the location of the warning light that indicates a system failure.

**Ammeter/Voltmeter** Check the gauge for cracks and cleanliness. Amps/Volts should come up to normal within seconds after the engine is started. If no gauge, identify the location of the warning light that indicates a system failure.

**Air Brake** Build air pressure up to 100-120 PSI, cut engine off and release all brakes, press hard on the foot brake and hold down for one minute, air pressure should not drop over four PSI. Turn ignition key on and continue with foot brake pumping air pressure down. At around 60 PSI the "Low Air" buzzer should sound and/or a warning light should appear. Keep pumping air down with foot brake, and at about 40 PSI, the release valves should pop out for the trailer and the truck.

**Hydraulic Brake (if equipped)** Pump the brake pedal three times, apply firm pressure to the pedal and hold for five seconds. The pedal should not move. If it does, there may be a leak.

**Steering Play** Check steering wheel play of no more than ten degrees (approximately two inches of movement at the rim of a 20-inch steering wheel).

**Parking Brake** Set the parking brake, put the vehicle in low gear and gently release your foot from the brake pedal (and clutch if equipped), until you feel the vehicle pulling against the brake. The vehicle should not move.

**Mirrors/Windshield** Check mirrors for proper adjustment. Check the windshield for cracks, cleanliness and illegal stickers.

**Wipers** Check the wipers for looseness, dry rot and function.

**Lighting Indicators** Check the following for function: panel light, high/low beam indicator, left and right turn signal indicators and four-way flasher indicator.

**Horns** Check both the highway and city horns for proper function.

**Heater/Defroster** Check both the defroster and heater fans for proper function.

This page is designed to be removed from the manual for reference while studying for the vehicle inspection portion of the CDL road test.

## Section 1: General Knowledge

Safety/Emergency Equipment      Ensure working fire extinguisher properly charged and mounted, spare electrical fuses (unless equipped with circuit breakers), three reflective triangles.

### Front Suspension

Springs      Check for missing, cracked, shifted or bent springs. If 1/4 or more are missing, your vehicle could be put out of service.

Spring Mount(s)      Check both mounts and the U bolts for cracks, non-factory welds, missing or loose bolts and nuts.

Shock Absorber      Check for cracks, leaks and missing bolts.

### Front Wheel

Rims      Check the rims for bends, cracks and nonfactory welds.

Hub Seal      Check the hub oil seal for missing bolts, cracks, leaks and proper level (if equipped with site glass).

Tire      Check the tire for at least 4/32" tread depth in the major grooves. Check for cuts, bulges and proper air pressure using an air gauge.

Lug Nuts      Check the lug nuts for missing, loose nuts and rust around them.

### Front Brakes

Slack Adjuster      Check the slack adjuster for missing cotter pins. If the slack adjuster moves more than one inch where the push rod attaches to it, it probably needs to be adjusted. Slack adjusters should not be at more than a 90-degree angle with the brakes applied.

Chambers      Check the chambers for cracks, dents and air leaks.

Air Hose      Check the hoses for loose connections, dry rot, holes and air leaks.

Brake Drum      Check the drum for cracks, non-factory welds and signs of grease or oil.

Hydraulic Brakes (if equipped)      Check the rotor for cracks, non-factory welds and signs of fluid leaks. Check the lines for cuts, holes, loose connections and fluid leaks. Check the calipers for cracks, missing/loose bolts and fluid leaks.

### Driver/Fuel Area

Door      Check the door for cracked or bent hinges and that it functions properly.

Mirrors      Check the mirrors for cracks, cleanliness and missing/loose bolts/nuts.

Fuel Tank      Check the fuel tank for cracks, holes and that the straps are not loose or cracked. Shiny metal by straps could indicate a loose strap. Check under fuel tank for leaks.

### Under the Vehicle

Drive shaft      Check the drive shaft for cracks, non-factory welds, missing/loose bolts or nuts and proper lubrication.

Exhaust System      Check the exhaust system for cracks, holes, missing/loose bolts and nuts. Check for signs of soot, which can indicate an exhaust leak.

Frame      Check the vehicle frame for cracks, bends, nonfactory welds and rust.

Rear Suspension      Inspect this area the same as the front. Suspensions vary and all items should be checked for cracks, bent, non-factory welds, missing/loose bolts or nuts. Inspect walker beams, torsion bars and air bellows, if equipped.

Rear Wheels      Check the rear wheels the same as the front with the exception of the tire depth, it should be 2/32" in the major grooves. Check the space between the dual tires. Tires should not be touching and no sign of debris. If equipped with spacers, they should not be bent, cracked or nonfactory welds.

Rear Brakes      Inspect this area the same as the front of the vehicle.

Truck Only      Check air and electrical lines for leaks, cracks, signs of wear and proper connection. Check catwalk (if equipped) to make sure it is clear and not loose. Check all mounting bolts to make sure none are missing and are tight. Check safety latch to make sure it is locked in place. Check the platform that holds the pentle hook for cracks. Check that the release latch is engaged and in place. Check the pentle hook and ring to make sure of no cracks, bends and closed completely around ring. Check the chains to make sure they are attached and locked. Check the lights on the rear of truck for proper color, clean lenses/reflectors and cracks, missing screws and condensation. Also check for the function of left/right turn signals, brake lights and four-way flashers.

Front of Trailer      Check air and electrical lines for leaks, cracks, signs of wear and proper connection. Check headerboard for cracks and bends. Check lights and reflectors same as others.

Side of Trailer      Check landing gear for cracks, bends, fully raised and handle secure. Check lights/reflectors same as others. Check doors (if equipped) are secure and not missing hardware. Check tie downs (if equipped) for cracks, bends, secure and no missing hardware. Check the frame for cracks, bends, non-factory welds and rust.

Wheels, Suspension, and Brakes      Inspect area same as rear of truck.

Rear of Trailer      Check lights/reflectors same as others. Check doors/ties same as others. Check splash guards are secure, no missing hardware.

## Department of Motor Vehicles

## Vehicle Inspection Study Guide

## STRAIGHT TRUCK/SCHOOL BUS

During the actual tests, you will be expected to point to or touch each of the parts of your vehicle listed below. Name the part and explain what damage or problems you might find. The types of damages or problems are listed below and in the vehicle inspection section in the CDL Manual.

Note: All axles touching the ground on one side of the vehicle must be inspected.

**This study guide cannot be used during the actual pre-trip inspection portion of the skills test.**

## Front of Vehicle

**Lights** Check for proper color/clean lenses, cracks, missing screws and condensation. Also check for function, left/right turn signals, headlights, high/low beam and four-way flashers.

**Steering Box** Check for missing/loose bolts, cracks and nonfactory welds. Check for steering fluid leaks and torn or frayed hoses.

**Steering Linkage** Check the steering column, pitman arm and drag link for cracks, bends, non-factory welds, missing castle nuts/cotter pins and proper lubrication.

## Engine Compartment

**Oil Level** Check by pulling out the dipstick, wiping it and reinserting it, then pull out to look at the low and full marks to determine the level.

**Coolant Level** Observe the site glass or line markings for proper level. If not equipped, explain removing radiator cap for level. (**Do not remove cap.**)

**Power Steering Fluid** Observe the sight glass or line markings for proper level. If not equipped, open the cap and check for proper level.

**Water Pump** Check for missing/loose bolts, cracks, proper belt tension, cracked or frayed belts and coolant leaks.

**Alternator** Check for missing/loose bolts, cracks, proper belt tension, cracked or frayed belts, and cracked, burnt or loose wires.

**Air Compressor** Check for missing/loose bolts. Check belts for tension, cracked or frayed lines and leaks.

**Leaks** Look under the engine compartment for coolant, power steering, transmission and oil leaks.

**Hydraulic Brakes (if equipped)** Check the site glass or line on container for proper brake fluid. Check the master cylinder for cracks, leaks, check the brake lines for cracks, frays and brake fluid leaks.

Inside the Vehicle  
(start engine)

**Clutch/Gearshift** If standard, check for excessive play in clutch – no more than two inches. Check the gear ranges to ensure they engage. Check the boot for holes and dry rot. If automatic, check gearshift for ranges.

**Air Pressure Gauge** Check for cracks and cleanliness. Air pressure should build to a minimum of 100 PSI in both the primary and secondary system.

**Oil Pressure Gauge** Check the gauge for cracks and cleanliness. Oil pressure should come up to normal within seconds after the engine is started. If no gauge, identify the location of the warning light that indicates a system failure.

**Ammeter/Voltmeter** Check the gauge for cracks and cleanliness. Amps/Volts should come up to normal within seconds after the engine is started. If no gauge, identify the location of the warning light that indicates a system failure.

**Air Brake** Build air pressure up to 100-120 PSI, cut engine off and release all brakes, press hard on the foot brake and hold down for one minute, air pressure should not drop over four PSI. Turn ignition key on and continue with foot brake pumping air pressure down. At around 60 PSI the “Low Air” buzzer should sound and/or a warning light should appear. Keep pumping air down with foot brake, and at about 40 PSI, the release valves should pop out for the trailer and the truck.

**Hydraulic Brake (if equipped)** Pump the brake pedal three times, apply firm pressure to the pedal and hold for five seconds. The pedal should not move. If it does, there may be a leak.

**Steering Play** Check steering wheel play of no more than ten degrees (approximately two inches of movement at the rim of a 20-inch steering wheel).

**Parking Brake** Set the parking brake, put the vehicle in low gear and gently release your foot from the brake pedal (and clutch if equipped), until you feel the vehicle pulling against the brake. The vehicle should not move.

**Mirrors/Windshield** Check mirrors for proper adjustment. Check the windshield for cracks, cleanliness and illegal stickers.

**Wipers** Check the wipers for looseness, dry rot and function.

**Lighting Indicators** Check the following for function: panel light, high/low beam indicator, left and right turn signal indicators and four-way flasher indicator.

**Horns** Check both the highway and city horns for proper function.

**Heater/Defroster** Check both the defroster and heater fans for proper function.

This page is designed to be removed from the manual for reference while studying for the vehicle inspection portion of the CDL road test.

## Section 1: General Knowledge

Safety/Emergency Equipment      Ensure working fire extinguisher properly charged and mounted, spare electrical fuses (unless equipped with circuit breakers), three reflective triangles.

### Front Suspension

Springs      Check for missing, cracked, shifted or bent springs. If 1/4 or more are missing, your vehicle could be put out of service.

Spring Mount(s)      Check both mounts and the U bolts for cracks, non-factory welds, missing or loose bolts and nuts.

Shock Absorber      Check for cracks, leaks and missing bolts.

### Front Wheel

Rims      Check the rims for bends, cracks and nonfactory welds.

Hub Seal      Check the hub oil seal for missing bolts, cracks, leaks and proper level (if equipped with site glass).

Tire      Check the tire for at least 4/32" tread depth in the major grooves. Check for cuts, bulges and proper air pressure using an air gauge.

Lug Nuts      Check the lug nuts for missing, loose nuts and rust around them.

### Front Brakes

Slack Adjuster      Check the slack adjuster for missing cotter pins. If the slack adjuster moves more than one inch where the push rod attaches to it, it probably needs to be adjusted. Slack adjusters should not be at more than a 90-degree angle with the brakes applied.

Chambers      Check the chambers for cracks, dents and air leaks.

Air Hose      Check the hoses for loose connections, dry rot, holes and air leaks.

Brake Drum      Check the drum for cracks, non-factory welds and signs of grease or oil.

**Hydraulic Brakes** (if equipped)      Check the rotor for cracks, non-factory welds and signs of fluid leaks. Check the lines for cuts, holes, loose connections and fluid leaks. Check the calipers for cracks, missing/loose bolts and fluid leaks.

### Driver/Fuel Area

Door      Check the door for cracked or bent hinges and that it functions properly.

Mirrors      Check the mirrors for cracks, cleanliness and missing/loose bolts/nuts.

Fuel Tank      Check the fuel tank for cracks, holes and that the straps are not loose or cracked. Shiny metal by straps could indicate a loose strap. Check under fuel tank for leaks.

### Under the Vehicle

Drive shaft      Check the drive shaft for cracks, non-factory welds, missing/loose bolts or nuts and proper lubrication.

Exhaust System      Check the exhaust system for cracks, holes, missing/loose bolts and nuts. Check for signs of soot, which can indicate an exhaust leak.

Frame      Check the vehicle frame for cracks, bends, nonfactory welds and rust.

### Rear of Vehicle

Rear Wheels      Check the rear wheels the same as the front with the exception of the tire depth, it should be 2/32" in the major grooves. Check the space between the dual tires. Tires should not be touching and no sign of debris. If equipped with spacers, they should not be bent, cracked or nonfactory welds.

Rear Suspension      Inspect this area the same as the front. Suspensions vary and all items should be checked for cracks, bent, non-factory welds, missing/loose bolts or nuts. Inspect walker beams, torsion bars and air bellows, if equipped.

Rear Brakes      Inspect this area the same as the front of the vehicle.

Rear Lights      Check for proper color and clean lenses/reflectors, cracks, missing screws and condensation. Also check for function of left/right turn signals, brake lights, reverse lights and four way flashers.

### If Passenger Vehicle Also Inspect:

Passenger Entry      Check that steps and handrails secure, no missing hardware, no worn matting, door opens and closes correctly.

Seating      Check that all seats are secure with no missing hardware.

Emergency Exits      Check the function of all exits both inside and out, including all warning devices.

Baggage Compartment (if equipped)      Check that doors open and close correctly and are secure with no missing hardware.

Department of Motor Vehicles

**Vehicle Inspection Study Guide****COACH/TRANSIT BUS**

During the actual tests, you will be expected to point to or touch each of the parts of your vehicle listed below. Name the part and explain what damage or problems you might find. The types of damages or problems are listed below and in the vehicle inspection section in the CDL Manual.

Note: All axles touching the ground on one side of the vehicle must be inspected.

**This study guide cannot be used during the actual pre-trip inspection portion of the skills test.**

**Front of Vehicle**

**Lights** Check for proper color/clean lenses, cracks, missing screws and condensation. Also check for function, left/right turn signals, headlights, high/low beam and four-way flashers.

**Engine Compartment**

**Oil Level** Check by pulling out the dipstick, wiping it and reinserting it, then pull out to look at the low and full marks to determine the level.

**Coolant Level** Observe the site glass or line markings for proper level. If not equipped, explain removing radiator cap for level. **(Do not remove cap.)**

**Power Steering Fluid** Observe the sight glass or line markings for proper level. If not equipped, open the cap and check for proper level.

**Water Pump** Check for missing/loose bolts, cracks, proper belt tension, cracked or frayed belts and coolant leaks.

**Alternator** Check for missing/loose bolts, cracks, proper belt tension, cracked or frayed belts, and cracked, burnt or loose wires.

**Air Compressor** Check for missing/loose bolts. Check belts for tension, cracked or frayed lines and leaks.

**Leaks** Look under the engine compartment for coolant, power steering, transmission and oil leaks.

**Inside the Vehicle (start engine)**

**Clutch/Gearshift** If standard, check for excessive play in clutch – no more than two inches. Check the gear ranges to ensure they engage. Check the boot for holes and dry rot. If automatic, check gearshift for ranges.

**Air Pressure Gauge** Check for cracks and cleanliness. Air pressure should build to a minimum of 100 PSI in both the primary and secondary system.

**Inside the Vehicle (continued)**

**Oil Pressure Gauge** Check the gauge for cracks and cleanliness. Oil pressure should come up to normal within seconds after the engine is started. If no gauge, identify the location of the warning light that indicates a system failure.

**Ammeter/Voltmeter** Check the gauge for cracks and cleanliness. Amps/Volts should come up to normal within seconds after the engine is started. If no gauge, identify the location of the warning light that indicates a system failure.

**Air Brake** Build air pressure up to 100-120 PSI, cut engine off and release all brakes, press hard on the foot brake and hold down for one minute, air pressure should not drop over three PSI. Turn ignition key on and continue with foot brake pumping air pressure down. At around 60 PSI the “Low Air” buzzer should sound and/or a warning light should appear. Keep pumping air down with foot brake, and at about 40 PSI, the parking brake knob should pop out.

**Steering Play** Check steering wheel play of no more than ten degrees (approximately two inches of movement at the rim of a 20-inch steering wheel).

**Parking Brake** Set the parking brake, put the vehicle in low gear and gently release your foot from the brake pedal (and clutch if equipped), until you feel the vehicle pulling against the brake. The vehicle should not move.

**Mirrors/Windshield** Check mirrors for proper adjustment. Check the windshield for cracks, cleanliness and illegal stickers.

**Wipers** Check the wipers for looseness, dry rot and function.

**Lighting Indicators** Check the following for function: panel light, high/low beam indicator, left and right turn signal indicators and four-way flasher indicator.

**Horns** Check both the highway and city horns for proper function.

**Heater/Defroster** Check both the defroster and heater fans for proper function.

**Safety/Emergency Equipment** Ensure working fire extinguisher properly charged and mounted, spare electrical fuses (unless equipped with circuit breakers), three reflective triangles.

**Front Suspension/Air Brakes** Listen for air leaks in the brakes and in the suspension.

This page is designed to be removed from the manual for reference while studying for the vehicle inspection portion of the CDL road test.

## Section 1: General Knowledge

<b>Front Wheels</b>	
Rims	Check the rims for bends, cracks and nonfactory welds.
Hub Seal	Check the hub oil seal for missing bolts, cracks, leaks and proper level (if equipped with site glass).
Tire	Check the tire for at least 4/32" tread depth in the major grooves. Check for cuts, bulges and proper air pressure using an air gauge. Cannot have recaps or retreads.
Lug Nuts	Check the lug nuts for missing, loose nuts and rust around them.
<b>Driver/Fuel Area</b>	
Door/Window	Check the door for cracked or bent hinges and that it functions properly.
Mirrors	Check the mirrors for cracks, cleanliness and missing/loose bolts/nuts.
Fuel Area	Check cap is tight and no fuel leaks.
<b>Rear of Vehicle</b>	
Rear Wheels	Check the rear wheels the same as the front with the exception of the tire depth, it should be 2/32" in the major grooves. Check the space between the dual tires. Tires should not be touching and no sign of debris. If equipped with spacers, they should not be bent, cracked or nonfactory welds.
Rear Suspension/ Air Brakes	Inspect the same as the front.
Lights	Check for proper color and clean lenses/reflectors, cracks, missing screws and condensation. Also check for function of left/right turn signals, brake lights, reverse lights and four-way flashers.
Passenger Entry	Steps and handrails secure, no missing hardware, no worn matting, door opens and closes correctly.
Seating	Check that all seats are secure with no missing hardware.
Emergency Exits	Check the function of all exits both inside and out, including all warning devices.
Baggage Compartments (if equipped)	Check that doors open and close correctly and are secure with no missing hardware.

Department of Motor Vehicles

**Vehicle Inspection Study Guide****COMBINATION VEHICLES**

During the actual tests, you will be expected to point to or touch each of the parts of your vehicle listed below. Name the part and explain what damage or problems you might find. The types of damages or problems are listed below and in the vehicle inspection section in the CDL Manual.

Note: All axles touching the ground on one side of the vehicle must be inspected.

**This study guide cannot be used during the actual pre-trip inspection portion of the skills test.**

**Front of Vehicle**

**Lights** Check for proper color/clean lenses, cracks, missing screws and condensation. Also check for function, left/right turn signals, headlights, high/low beam and four-way flashers.

**Steering Box** Check for missing/loose bolts, cracks and nonfactory welds. Check for steering fluid leaks and torn or frayed hoses.

**Steering Linkage** Check the steering column, pitman arm and drag link for cracks, bends, non-factory welds, missing castle nuts/cotter pins and proper lubrication.

**Engine Compartment**

**Oil Level** Check by pulling out the dipstick, wiping it and reinserting it, then pull out to look at the low and full marks to determine the level.

**Coolant Level** Observe the site glass or line markings for proper level. If not equipped, explain removing radiator cap for level. (**Do not remove cap.**)

**Power Steering Fluid** Observe the sight glass or line markings for proper level. If not equipped, open the cap and check for proper level.

**Water Pump** Check for missing/loose bolts, cracks, proper belt tension, cracked or frayed belts and coolant leaks.

**Alternator** Check for missing/loose bolts, cracks, proper belt tension, cracked or frayed belts, and cracked, burnt or loose wires.

**Air Compressor** Check for missing/loose bolts. Check belts for tension, cracked or frayed lines and leaks.

**Leaks** Look under the engine compartment for coolant, power steering, transmission and oil leaks.

**Hydraulic Brakes (if equipped)** Check the site glass or line on container for proper brake fluid. Check the master cylinder for cracks, leaks, check the brake lines for cracks, frays and brake fluid leaks.

**Inside the Vehicle (start engine)**

**Clutch/Gearshift** If standard, check for excessive play in clutch—no more than two inches. Check the gear ranges to ensure they engage. Check the boot for holes and dry rot. If automatic, check gearshift for ranges.

**Air Pressure Gauge** Check for cracks and cleanliness. Air pressure should build to a minimum of 100 PSI in both the primary and secondary system.

**Oil Pressure Gauge** Check the gauge for cracks and cleanliness. Oil pressure should come up to normal within seconds after the engine is started. If no gauge, identify the location of the warning light that indicates a system failure.

**Ammeter/Voltmeter** Check the gauge for cracks and cleanliness. Amps/Volts should come up to normal within seconds after the engine is started. If no gauge, identify the location of the warning light that indicates a system failure.

**Air Brake** Build air pressure up to 100-120 PSI, cut engine off and release all brakes, press hard on the foot brake and hold down for one minute, air pressure should not drop over four PSI. Turn ignition key on and continue with foot brake pumping air pressure down. At around 60 PSI the "Low Air" buzzer should sound and/or a warning light should appear. Keep pumping air down with foot brake, and at about 40 PSI, the release valves should pop out for the trailer and the tractor.

**Hydraulic Brake (if equipped)** Pump the brake pedal three times, apply firm pressure to the pedal and hold for five seconds. The pedal should not move. If it does, there may be a leak.

**Steering Play** Check steering wheel play of no more than ten degrees (approximately two inches of movement at the rim of a 20-inch steering wheel).

**Parking Brake** Set the parking brake, put the vehicle in low gear and gently release your foot from the brake pedal (and clutch if equipped), until you feel the vehicle pulling against the brake. The vehicle should not move.

**Mirrors/Windshield** Check mirrors for proper adjustment. Check the windshield for cracks, cleanliness and illegal stickers.

**Wipers** Check the wipers for looseness, dry rot and function.

**Lighting Indicators** Check the following for function: panel light, high/low beam indicator, left and right turn signal indicators and four-way flasher indicator.

**Horns** Check both the highway and city horns for proper function.

**Heater/Defroster** Check both the defroster and heater fans for proper function.

This page is designed to be removed from the manual for reference while studying for the vehicle inspection portion of the CDL road test.

## Section 1: General Knowledge

Safety/Emergency Equipment Ensure working fire extinguisher properly charged and mounted, spare electrical fuses (unless equipped with circuit breakers), three reflective triangles.

**Front Suspension** Check for missing, cracked, shifted or bent springs. If 1/4 or more are missing, your vehicle could be put out of service.

Spring Mount(s) Check both mounts and the U bolts for cracks, non-factory welds, missing or loose bolts and nuts.

Shock Absorber Check for cracks, leaks and missing bolts.

### Front Wheels

Rims Check the rims for bends, cracks and nonfactory welds.

Hub Seal Check the hub oil seal for missing bolts, cracks, leaks and proper level (if equipped with site glass).

Tire Check the tire for at least 4/32" tread depth in the major grooves. Check for cuts, bulges and proper air pressure using an air gauge.

Lug Nuts Check the lug nuts for missing, loose nuts and rust around them.

### Front Brakes

Slack Adjuster Check the slack adjuster for missing cotter pins. If the slack adjuster moves more than one inch where the push rod attaches to it, it probably needs to be adjusted. Slack adjusters should not be at more than a 90-degree angle with the brakes applied.

Chambers Check the chambers for cracks, dents and air leaks.

Air Hose Check the hoses for loose connections, dry rot, holes and air leaks.

Brake Drum Check the drum for cracks, non-factory welds and signs of grease or oil.

**Hydraulic Brakes** (if equipped) Check the rotor for cracks, non-factory welds and signs of fluid leaks. Check the lines for cuts, holes, loose connections and fluid leaks. Check the calipers for cracks, missing/loose bolts and fluid leaks.

### Driver/Fuel Area

Door Check the door for cracked or bent hinges and that it functions properly.

Mirrors Check the mirrors for cracks, cleanliness and missing/loose bolts/nuts.

Fuel Tank Check the fuel tank for cracks, holes and that the straps are not loose or cracked. Shiny metal by straps could indicate a loose strap. Check under fuel tank for leaks.

### Under the Vehicle

Drive shaft Check the drive shaft for cracks, non-factory welds, missing/loose bolts or nuts and proper lubrication.

Exhaust System Check the exhaust system for cracks, holes, missing/loose bolts and nuts. Check for signs of soot, which can indicate an exhaust leak.

Frame Check the vehicle frame for cracks, bends, nonfactory welds and rust.

### Tractor Only

Air/Electrical Lines Check for leaks, cuts, cracks or sign of wear.

Catwalk Check to make sure it is clear and not loose.

Coupling System Check for loose or missing bolts, clamps, brackets or nuts.

Mounting Bolts Check for loose or missing nuts or bolts.

Safety Latch Ensure it is in position over locking lever and engaged.

Platform Check for cracks or breaks.

Release Arm Ensure it is locked in place.

Kingpin/Apron Ensure the kingpin is not bent, apron is not bent, cracked or broken. Locking jaws are closed around kingpin.

Sliding Fifth Wheel Ensure it is in locked position, not cracked or broken.

Locking Pins Check for loose or missing pins. None broken/damaged.

Lights/Reflector Ensure it is not cracked, lenses clear, clean, proper color, no condensation. Check for function, left/right turn signal, four-way flashers and brake.

### Rear of Vehicle

Rear Wheels Check the rear wheels the same as the front with the exception of the tire depth, it should be 2/32" in the major grooves. Check the space between the dual tires. Tires should not be touching and no sign of debris. If equipped with spacers, they should not be bent, cracked or non-factory welds.

Rear Suspension Inspect this area the same as the front. Suspensions vary and all items should be checked for cracks, bent, non-factory welds, missing/loose bolts or nuts. Inspect walker beams, torsion bars and air bellows, if equipped.

Rear Brakes Inspect this area the same as the front of the vehicle.

### Front of Trailer

Air/Electric Lines Ensure glad hands are secure and rubber seals not split, cracked or missing, electrical connection locked into place.

Header Board Ensure it is not cracked or bulged.

Lights/Reflectors Ensure it is not cracked, clear, clean, proper color, no condensation. Check for function.

### Side of Trailer

Landing Gear Check for missing, bent or cracked frames. Handle secured.

Lights/Reflectors Ensure it is not cracked, clear, clean, proper color, no condensation. Check for function.

Doors, Ties Ensure it opens and closes properly, hinges not cracked, ties not broken or missing.

Frame Ensure it is not bent or cracked, non-factory welds.

Wheels Check same as rear wheels.

Suspension Check the same as front suspension.

Brakes Check same as front brakes.

### Rear of Trailer

Lights/Reflectors Ensure it is not cracked, lenses clear, clean, proper color, no condensation. Check for function same as rear of tractor.

Door/Ties Ensure it opens and closes properly, hinges not cracked, ties not broken or missing.

Splash Guards Ensure it is secured, no nuts or bolts missing.

## Basic Control of Your Vehicle

To drive a vehicle safely, you must be able to control its speed and direction. Safe operation of a commercial vehicle requires skills in:

- ▶ Accelerating
- ▶ Steering
- ▶ Shifting gears

Be sure to apply the parking brake when you leave your vehicle.

### Accelerating

- ▶ Partly engage the clutch before taking your foot off the brake.
- ▶ Use the parking brake to keep from rolling back. Release it only when you have enough power to keep from rolling back.
- ▶ Speed up smoothly and gradually so the vehicle does not jerk. Sudden acceleration can cause mechanical damage. If you are pulling a trailer, sudden acceleration can damage the coupling.
- ▶ Speed up slowly when traction is poor, such as in rain or snow. If you use too much power, the drive wheels spin. If the drive wheels spin, let up on the accelerator.

### Steering

- ▶ Hold the steering wheel firmly with both hands.
- ▶ Your hands should be at the 9 o'clock and 3 o'clock position on the steering wheel.

### Backing Safely

Because you cannot see everything behind your vehicle, **backing is always dangerous**. Avoid backing whenever you can. When you must back, follow these safety rules:

- ▶ **Look at your path before you begin backing.** Get out of the vehicle and check your clearance to the sides and overhead.
- ▶ **Turn on four-way flashers and blow the horn** before backing.
- ▶ **Back slowly.** Use the lowest reverse gear.
- ▶ **Back and turn toward the driver's side.** This allows you to see better. You can watch the rear of your vehicle by looking out the side window. Use driver-side backing even if it means going around the block to put your vehicle in this position. The extra safety is worth it.
- ▶ **Use a helper.** A helper can check your blind spots for you. The helper should stand where he or she has a

view of the rear of the truck and where the driver can see the helper. If you lose sight of the helper, stop. He may be in a place of danger. Before you begin backing, agree on hand signals that you both understand.

### Backing with a Trailer

- ▶ When backing a car, straight truck or bus, you turn the top of the steering wheel in the direction that you want to go. When backing a trailer, turn the steering wheel in the opposite direction. Once the trailer starts to turn, you must turn the wheel the other way to follow the trailer.
- ▶ When you back a trailer, try to position your vehicle so you can back in a straight line. If you must back on a curved path, back to the driver's side so you can see.
- ▶ Back slowly.
- ▶ Use both mirrors. The mirrors help you see if the trailer is staying on the proper path. Correct the trailer's path by turning the top of the steering wheel in the direction of the drift.
- ▶ Pull forward. Make pull-ups to reposition your vehicle as needed.

### Shifting Gears—Manual Transmissions

**Basic method for shifting up:** Most heavy vehicles with manual transmissions require double clutching to change gears. This is the basic method:

- ▶ Release the accelerator. Push in the clutch and shift to neutral.
- ▶ Release the clutch
- ▶ Let the engine and gears slow to the RPM required for the next gear. (This takes practice.)
- ▶ Push in the clutch and shift to the higher gear.
- ▶ Release the clutch and press the accelerator at the same time.

Shifting gears using double clutching requires practice. If you remain too long in neutral, you may have trouble putting the vehicle into the next gear. Don't try to force it. Return to neutral, release the clutch, increase engine speed to match road speed and try again.

There are two ways to know when to shift up:

- ▶ **Engine speed (RPM).** Study the manual for your vehicle and learn the operating RPM range. Watch your tachometer and shift up when your engine reaches the top of the range.
- ▶ **Road speed (MPH).** Learn the speeds that each gear is good for. Then you can use the speedometer to know when to shift up.

## Section 1: General Knowledge

### Basic method for shifting down:

- ▶ Downshifting requires knowing when to shift. Use either the tachometer or the speedometer to decide when to downshift.
- ▶ Take your foot off the accelerator. Push in the clutch and shift to neutral.
- ▶ Release the clutch.
- ▶ Press the accelerator. Increase engine and gear speed to the RPM required in the lower gear.
- ▶ Push in the clutch and shift to the lower gear at the same time.
- ▶ Release the clutch and press the accelerator at the same time.

You should downshift:

- ▶ **Before starting down a hill:** Slow down and shift down to a speed that you can control without using the brakes hard. Make sure your gear is low enough. Usually you will use a lower gear than you would use to climb the same hill.
- ▶ **Before entering a curve:** Slow down to a safe speed. Downshift **before** you enter the curve. This helps you control your vehicle while turning. You can begin to accelerate as you leave the curve

### Retarders (Jake brake)—Electric or Hydraulic

Retarders help slow a vehicle so that you don't need to use your brakes as much. This reduces brake wear and gives you another way to slow your vehicle. All retarders can be turned on or off by the driver. When turned on, retarders apply their braking power whenever you take your foot completely off the accelerator. They apply braking power only to the drive wheels.

If your drive wheels have poor traction, the retarder may cause them to skid. Always turn off the retarder when the road is wet, icy or covered with snow, especially if the unit is empty or lightly loaded.

## Seeing

To be a safe driver, you need to know what's going on all around your vehicle.

### Look Ahead

Because stopping or changing lanes may take a lot of distance, you must know what the traffic is doing on all sides of you. Expert drivers look far ahead so they will know how much room they have to move. They try to focus their eyes 12 to 15 seconds ahead. In the city, this equals approximately one block. On the highway, this equals approximately  $\frac{1}{4}$  of a mile. When you scan ahead, check for traffic, road conditions, sharp pavement drop-offs and signs. Also look for slow-moving vehicles. These vehicles may be marked with a

red triangle with an orange center. Be especially careful when driving through work zones.

Looking ahead doesn't mean that you aren't paying attention to other things going on around you. Good drivers shift their attention back and forth, near and far.

Remember you're the expert. Anticipate trouble and leave yourself a place to go if a hazard appears suddenly. A hazard is anyone or anything that can cause an unsafe condition. The best drivers are defensive and prepared for hazards.

### Use Your Mirrors

Look in your mirrors to check the traffic around you and to check your vehicle. Check your mirrors when you change lanes, turn or merge. Check your mirrors quickly and return your attention to the road ahead.

Use your mirrors to check your tires. If you are carrying open cargo, use the mirrors to check it. Look for loose straps, ropes or chains. Watch for a flapping or ballooning tarp.

Blind spots are danger areas, which cannot be seen in your mirrors. Therefore, many vehicles have curved mirrors that show a wider area than flat mirrors. Remember, everything in a curved mirror appears **smaller** than it really is. Objects also seem farther away than they really are.

Always make mirror adjustments before you start your trip. Mirrors can only be checked accurately when the trailer(s) is straight.

## Communicating

It is important to know what is going on around your vehicle. But, it is also important to let others know what you are doing. Use your vehicle to communicate with other drivers. You can communicate with your headlights, brake lights, signal lights and horn.

### Signal Ahead

- ▶ Signal early.
- ▶ Signal before you turn, merge or change lanes.
- ▶ Brake early and slow gradually for turns.
- ▶ Flash your brake lights to warn other drivers that you need to slow down or stop. Don't stop suddenly.
- ▶ Turn off your signal after you make the turn, merge or lane change.
- ▶ Use your 4-way emergency flashers when moving slowly or when you are parked.
- ▶ Don't signal other drivers to pass you. This could cause a crash.

### Pass with Caution

- ▶ Check your side mirrors for traffic approaching you from behind.
- ▶ Check ahead. Do you have sufficient room to pass?
- ▶ Use your turn signal.
- ▶ Just before you begin passing, check your mirrors and blind spots once more for approaching traffic.

### Communicate Your Presence to Others

- ▶ Don't assume that other drivers, bicyclists, or pedestrians can see or hear your vehicle.
- ▶ Use your low beam headlights at dawn and dusk. Use your low beam headlights in fog, rain or snow so other drivers will see you.
- ▶ When you pass, tap your horn lightly.
- ▶ Use your horn only when needed. Otherwise, your horn may scare others.
- ▶ When you stop on the side of the road:
  - ▶ Turn on your 4-way emergency flashers.
  - ▶ Place reflective triangles or flares within 10 minutes of stopping. Place them as shown in the following diagrams.

If you stop on a road or the shoulder of any road, you must put out emergency warning devices (reflective triangles or flares) within 10 minutes. Place the warning devices in the following locations.

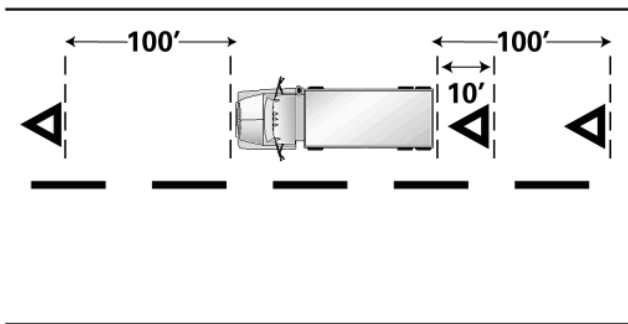

**On two-lane roads carrying traffic in both directions or on an undivided highway,** place warning devices within ten feet of the front or rear corners of your vehicle. Place a warning device 100 feet behind or ahead of your vehicle. Place it on the shoulder or in the lane where you stopped.

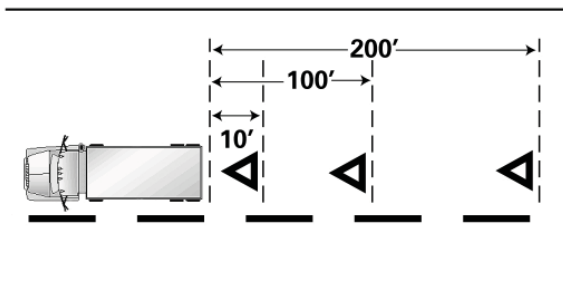

**On a one-way or divided highway,** place warning devices 10 feet, 100 feet and 200 feet behind your vehicle.

Place a warning device before any hill, curve or anything else that prevents other drivers from seeing your vehicle with 500 feet.

**When you place the triangles, hold them between yourself and the oncoming traffic. This helps ensure your safety.**

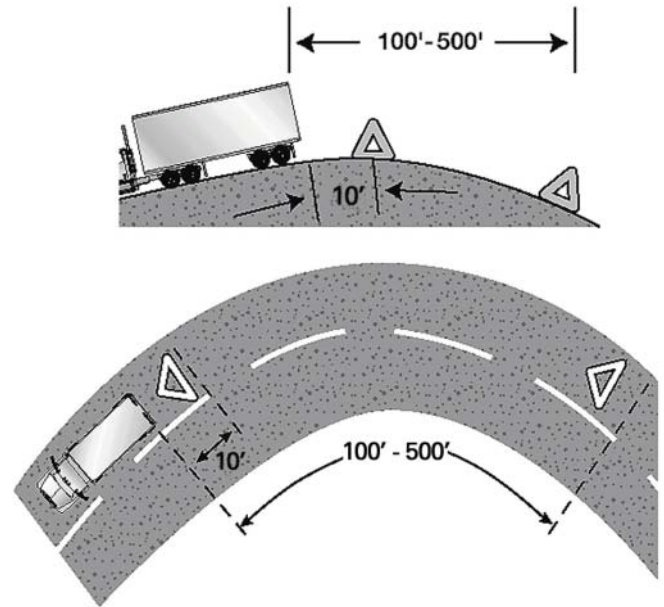

### Managing Space

To be a safe driver, you need space all around your vehicle. When something goes wrong, space gives you time to think and to take action. While this is true for all vehicles, it is very important for large vehicles. Large vehicles require more space for stopping and turning.

### Space Ahead

You need space in front of you in case you must stop suddenly. In crashes, trucks and buses most often hit the vehicle in front of them. This is because they were following too closely. If the vehicle ahead of you is smaller than your vehicle, it can probably stop faster than you can. If you follow too closely, you could hit it if the driver stops suddenly.

#### The rule of seconds

- ▶ If you are driving below 40 mph, maintain at least one second for each 10 feet of vehicle length.
- ▶ At speeds over 40 mph, add an extra second for safety.

#### Here's how it works.

- ▶ Watch the vehicle ahead pass a fixed point, such as an overpass, sign, fence, corner or other marker.
- ▶ Begin counting off the seconds it takes you to reach the same place in the road.
- ▶ If you reach the mark before you have counted off the correct number of seconds, you're following too closely. Slow down and increase your following distance.

## Section 1: General Knowledge

### Examples:

- ▶ If you are driving a 40-foot vehicle at speeds under 40 mph, leave 4 seconds between you and the vehicle ahead. One second for each 10 feet of vehicle length =  $1 \times 4$  or 4 seconds.
- ▶ If you are driving a 40-foot vehicle at speeds over 40 mph, leave 5 seconds between you and the vehicle ahead. One second for each 10 feet of vehicle length plus an additional second for safety:  $1 \times 4 = 4$  plus an extra second for safety = 5 seconds.
- ▶ If you are driving a 60-foot vehicle at speeds under 40 mph, leave 6 seconds between you and the vehicle ahead. One second for each 10 feet of vehicle length =  $1 \times 6$  or 6 seconds.
- ▶ If you are driving a 60-foot vehicle at speeds over 40 mph, leave 7 seconds between you and the vehicle ahead. One second for each 10 feet of vehicle length plus an additional second for safety:  $1 \times 6 = 6$  plus an extra second for safety = 7 seconds.

**Remember, the rule of seconds applies only in good weather and depends on the condition of your vehicle and the road. In bad weather, heavy traffic, poor pavement or if your vehicle is in poor condition, add extra seconds to your following distance.**

### Space Behind

You can't keep other drivers from following you too closely. But you can take action to increase your safety.

**Stay to the right.** Drivers often tailgate when heavy vehicles can't keep up with traffic. If a heavy load slows you down, stay in the right lane. If you are going uphill, do not pass other slow vehicles unless you can pass quickly and safely.

### Deal with tailgaters safely.

- ▶ Avoid quick changes. Before you slow down or turn, signal early and reduce your speed gradually.
- ▶ Increase your following distance. Extra space in front of your vehicle can help you avoid sudden stops. It also makes it easier for the tailgater to pass you.
- ▶ Don't speed up. It's safer to be tailgated at a low speed than at a high speed.
- ▶ Avoid tricks. Don't turn on your tail lights or flash your brake lights.

### Space to the Sides

- ▶ Keep your vehicle centered in the lane and maintain safe clearance on either side.
- ▶ Avoid traveling beside other vehicles. In heavy traffic, keep as much space as possible between your vehicle and other vehicles. If you must travel alongside another vehicle, drop back or pull forward so that you are sure the other driver can see you.

- ▶ High winds may cause your vehicle to sway. This problem is worse for lighter vehicles, such as empty trucks. High winds may be especially bad coming out of tunnels.

### Space Overhead

Because commercial vehicles are larger than most vehicles, watch out for overhead objects. Make sure you always have overhead clearance.

- ▶ The weight of a loaded vehicle changes its height. An empty vehicle is taller than a loaded one.
- ▶ Before backing, get out of the vehicle and check for overhanging objects such as trees, branches or electric wires. It's easy to miss these things when backing.
- ▶ Don't assume that the heights posted at bridges and overpasses are correct. Repaving or packed snow may have reduced the clearance since the signs were posted.
- ▶ **If you are not sure that you have space to pass under an object, take another route.**

### Space for Turns

Because of wide turning and offtracking, large vehicles can hit other vehicles or objects during turns.

Definition: Trailer wheels follow a different path than the tractor wheels. This is called offtracking.

### When turning right:

- ▶ Turn slowly to give yourself and others time to avoid problems.
- ▶ If you cannot make the right turn without swinging into another lane, turn wide as you complete the turn. Refer to the diagram. Keep the rear of your vehicle close to the curb. This will stop other drivers from passing you on the right.

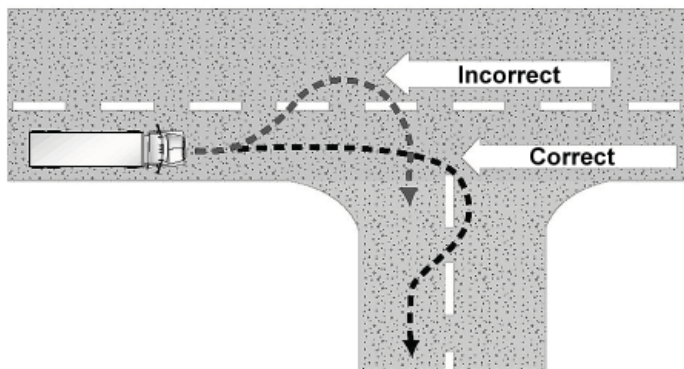

- ▶ Don't turn to the left as you start the turn. The driver behind you may think you are turning left and try to pass you on the right.
- ▶ If you must cross into an oncoming lane to make a turn, watch out for vehicles coming toward you. Give them room to pass or stop. However, don't back up for them. You could hit the vehicle behind you.

**When turning left:**

- ▶ Reach the center of the intersection before you begin your turn. If you turn too soon, your vehicle could hit another vehicle because of offtracking.
- ▶ If there are two lanes, always use the right turn lane. Don't begin a left turn in the left lane because you may have to swing right to complete the turn. You can see drivers on your left easier than those on your right.

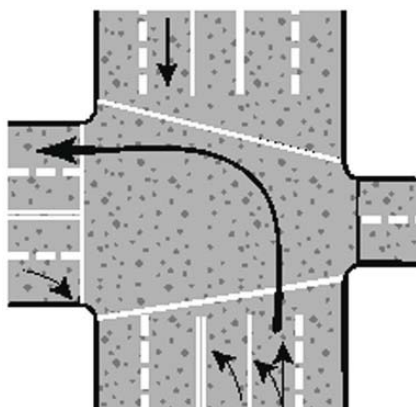

- ▶ **Braking distance** is the distance it takes the vehicle to stop once you hit the brakes. At 55 mph on dry pavement, it takes a vehicle with good brakes about 2.5 seconds to stop. Within that time, the vehicle will travel another 192 feet.
- ▶ **Total stopping distance;** traveling at 55 mph, it will take about 4 seconds to stop your vehicle. The vehicle will travel approximately 312 feet before coming to a stop. That's longer than the length of a football field.

**Space to Cross or Enter Traffic**

Keep these points in mind when crossing or entering traffic:

- ▶ Because commercial vehicles are larger and accelerate more slowly than passenger cars, you may need a much larger gap to enter traffic.
- ▶ Acceleration varies with your load. Allow more room if your vehicle is fully loaded.
- ▶ Before you begin across a road, make sure you can get all the way across before traffic reaches you.

**Controlling Speed**

Driving too fast is a major cause of crashes and fatalities. You must adjust your speed to suit weather conditions, the road (such as hills and curves), visibility and traffic.

**Speed and Stopping**

Three things add up to total stopping distance.

Perception distance  
 Reaction distance  
 Braking distance  
 = Total stopping distance.

- ▶ **Perception distance** is the distance your vehicle travels from the time your eyes see a hazard until your brain recognizes it. Perception time for an alert driver is about 3/4 second. At 55 mph, you travel 60 feet in 3/4 second.
- ▶ **Reaction distance** is the distance traveled from the time your brain tells your foot to move from the accelerator until the time your foot pushes the brake pedal. An average driver reacts within 3/4 second. This adds an additional 60 feet to the distance traveled.

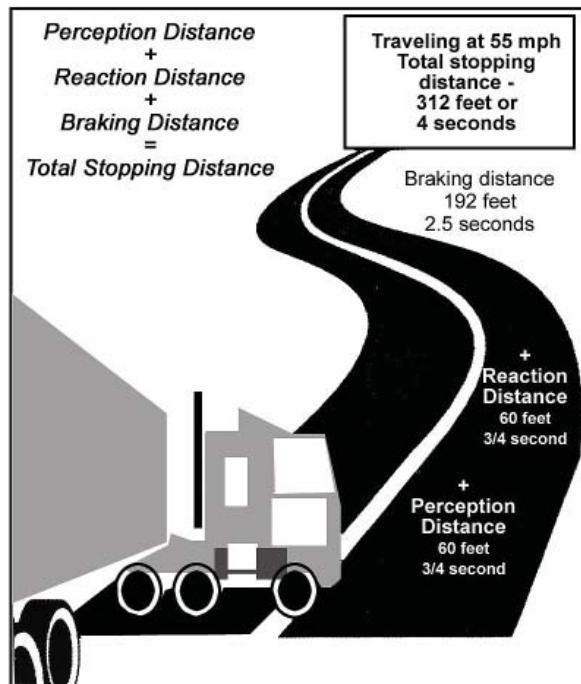

**Rules of Thumb**

- ▶ When you double your speed, it takes four times as much distance to stop your vehicle; your vehicle will have four times the destructive power in a crash.
- ▶ You can't steer or brake a vehicle unless you have traction. Traction is the friction between the tires and the road. Reduce your speed on wet and slippery roads.
- ▶ Wet roads can double stopping distance. Reduce your speed by about 1/3 on a wet road. For example slow down from 55 mph to 35 mph.
- ▶ On packed snow, reduce your speed by 1/2 or more.
- ▶ If the road is icy, reduce your speed to a crawl. Stop driving as soon as you can.
- ▶ Empty trucks require greater stopping distance. An empty vehicle has less traction. The brakes are designed to control the maximum weight of the unit; therefore, the brakes lock up more readily when the trailer is empty or lightly loaded. This can cause skidding and loss of control.

## Section 1: General Knowledge

### Slippery when wet

- ▶ Shady parts of a road will remain icy and slippery long after open areas have melted.
- ▶ Bridges freeze before the road freezes. Be careful when the temperature is around 32 degrees F.
- ▶ Slight melting makes ice wet. Wet ice is more slippery than ice that is not wet.
- ▶ Black ice is a thin layer that is clear enough that you can see the road underneath. It makes the road look wet. When the temperature is below freezing and the road looks wet, watch for black ice.
- ▶ If ice is on the front of your mirror, mirror support or antenna, the road surface is probably starting to ice up.
- ▶ Roads are very slippery when rain first begins. Just after rain begins, water mixes with oil on the road making it unusually slippery.

**Hydroplaning** – In some weather, water or slush collects on the road. When this happens, your vehicle can hydroplane. The tires lose contact with the road and have little or no traction. You may not be able to steer or brake. Hydroplaning can occur at speeds as low as 30 mph. Hydroplaning is more likely if tire pressure is low or the tread is worn.

- ▶ Take your foot off the accelerator and push in the clutch.
- ▶ This will slow your vehicle and let the wheels turn freely.
- ▶ Do not use the brakes to slow down.
- ▶ If the drive wheels begin to skid, push the clutch to let them turn freely.

### Speed and Curves

If you take a curve too fast, your tires can lose traction with the road. This could cause your vehicle to skid off the road or roll over. Tests show that trucks with a high center of gravity can roll over at the posted speed limit for a curve.

- ▶ Slow to a safe speed before you enter a curve.
- ▶ Braking in a curve is dangerous because you can lock the wheels and cause a skid.
- ▶ Never exceed the posted speed limit for a curve.
- ▶ Downshift to a gear that will let you accelerate slightly in the curve. This will help you keep control.

### Speed and Distance Ahead

- ▶ You should always be able to stop within the distance you can see ahead.
- ▶ Fog, rain or other conditions may require you to slow down.
- ▶ At night, you can't see as far with low beams as you can with high beams. When you use low beams, slow down.

### Speed on Downgrades

- ▶ As you go downhill, your vehicle's speed increases.
- ▶ Never exceed the maximum safe speed on a downgrade.
- ▶ Downshift to a low gear before starting down a grade.
- ▶ You must use the braking effect of the engine to control your speed on downgrades. The engine's braking effect is greatest when it is near the governed RPMs and the transmission is in a low gear.
- ▶ Save your brakes so that you can slow or stop as required by road and traffic conditions.

### Maximum Speed Limits for Commercial Motor Vehicles

Vehicle Type	Interstate Highways	Limited Access Highways	Non-limited Access Highways		School, Business or Residential Zones	Highways Designated as a Rural Rustic Road
			Four or More Lanes	Less Than Four Lanes		
<b>Trucks</b>	Up to 70 mph, as posted	55 mph	55 mph	45 mph (2)	25 mph (3) (4)	35 mph (5)
<b>Passenger Buses</b>	Up to 70 mph, as posted	55 mph	55 mph	55 mph	25 mph (3) (4)	35 mph (5)
<b>School Buses</b>	Maximum 60 mph where the posted speed limit is more than 55 mph	45 mph (1)	45 mph (1)	45 mph (1)	25 mph (3) (4)	35 mph (5)

(1) A school bus may travel 45 mph or the minimum speed allowable, if the posted speed limit is 55 mph or less. A school bus may travel up to 60 mph on an interstate or any other highway where the posted speed limit is more than 55 mph.

(2) Unless otherwise posted and driving conditions permit, the maximum speed limit is 45 mph on all public roads except primary highways (Routes 1-599) and the Interstate.

(3) Localities may increase or decrease the 25 mph speed limit in school zones. You may travel up to the posted speed limit.

(4) You may travel 25 mph or up to the posted speed limit on highways in business or residential districts.

(5) Some highways designated as rural rustic roads may have posted speed limits other than 35 mph. You may drive up to the speed limit on those roads.

## Braking

Emergency braking does not mean pushing down on the brake pedal as hard as you can. That will lock the wheels and cause a skid. Instead, brake so that you keep your vehicle in a straight line. You can use the controlled braking method or the stab braking method.

### Controlled Braking

- ▶ Apply the brakes as hard as you can **without** locking the wheels.
- ▶ Steer as little as possible.
- ▶ If you need to steer harder or if the wheels lock, release the brakes.
- ▶ Reapply the brakes as soon as possible.

### Stab Braking

- ▶ Use stab braking only on vehicles that do not have anti-lock brake systems.
- ▶ Apply your brakes fully.
- ▶ Release the brakes when the wheels lock up.
- ▶ As soon as the wheels start rolling, apply the brakes fully again. It can take up to one second for the wheels to start rolling after you release the brakes. If you reapply the brakes before the wheels start rolling, the vehicle will not straighten out.

## Steering to Avoid a Crash

Stopping is not always the safest thing to do in an emergency. If you don't have enough room to stop, you may have to steer away from what's ahead. Many times you can turn to miss an obstacle more quickly than you can stop. Often, steering to avoid an obstacle is the best answer in an emergency situation. However, top-heavy vehicles and tractors with multiple trailers may roll over. When steering to avoid a crash, take the following steps.

- ▶ Keep both hands on the steering wheel.
- ▶ Do not apply the brakes while you are turning. Applying the brakes could lock your wheels and cause you to skid out of control.
- ▶ Do not turn more than you need. The more sharply you turn, the greater the risk of turning over or skidding.
- ▶ Be ready to countersteer as soon as you have passed whatever was in your path.

Definition: Countersteer means to turn your wheel in the opposite direction. Emergency steering and countersteering are two parts of one driving action.

In some emergencies, you may have to drive off the road. Most shoulders are strong enough to support the weight of a large vehicle and offer an escape route. Follow these steps if you must drive off the road.

- ▶ Avoid braking until your speed has dropped to about 20 mph. Then brake gently to avoid skidding.
- ▶ Keep one set of wheels on the pavement if possible. This helps you to maintain control.
- ▶ Stay on the shoulder until your vehicle comes to a stop. Signal and check your mirrors before returning to the road.
- ▶ If you must return to the road before you stop, hold the wheel tightly and turn sharply enough to get back on the road safely. Don't try to edge on to the road gradually. This could cause you to lose control. As soon as both front tires are on the paved surface, countersteer immediately.

## Skid Control and Recovery

A skid happens when the tires lose their grip on the road. The best way to stop any skid is to restore traction to the tires. The four main causes of skids are:

- ▶ **Overbraking.** Braking too hard can lock the wheels causing a skid. Skids may also happen if you use the speed retarder when the road is slippery.
- ▶ **Oversteering** or turning the wheels too sharply may cause a skid.
- ▶ **Overacceleration** or supplying too much power to the drive wheels can cause them to spin.
- ▶ **Driving too fast.** Most serious skids result from driving too fast for road conditions. Drivers who adjust their driving to fit the conditions don't have to overaccelerate, brake hard or oversteer to avoid hazards.

**Rear-wheel (drive-wheel) skids** are the most common types of skid. They are caused by overacceleration or overbraking.

- ▶ **Overacceleration skids** usually happen on ice or snow. Stop the skid by taking your foot off the accelerator. If the road is slippery, push in the clutch. This allows the wheels to roll freely and regain traction.
- ▶ **Overbraking skids** happen when the rear drive wheels lock. Locked wheels have less traction than rolling wheels and usually slide sideways. A bus or straight truck will slide sideways. A vehicle towing a trailer will jackknife. Take the following actions to stop a rear-wheel braking skid:
  - ▶ Stop braking. This will let the rear wheels roll and keep them from sliding further. If you are on a slippery surface, push in the clutch to let the wheels turn freely.
  - ▶ Turn quickly. If your vehicle begins to slide sideways, quickly steer in the direction you want the vehicle to go.

## Section 1: General Knowledge

- ▶ **Countersteer.** As soon as your vehicle begins to move in the correct direction, turn the steering wheel quickly in the opposite direction. This will prevent a skid in the opposite direction. Be careful not to over-correct.

**Front wheel skids** are often caused by driving too fast for the conditions. In a front wheel skid, the front of the vehicle continues in a straight line no matter how much you turn the steering wheel. You may not be able to steer around a curve or turn. Lack of tread on the front tires and cargo loaded incorrectly may also cause front-wheel skids.

- ▶ The only way to stop a front-wheel skid is to let your vehicle slow down.
- ▶ Stop turning and hard braking.
- ▶ Slow down as quickly as possible without skidding.

## Hazardous Conditions

Driving becomes hazardous when visibility is reduced or when the road surface is covered with rain, snow or ice. Reduce your speed and increase your following distance.

## Night Driving

Three factors affect safe driving at night: the driver, the roadway and the vehicle.

**The driver:** Your vision and the vision of other drivers is not as sharp in low light conditions. Drivers can also be blinded for a short time by the lights of oncoming vehicles. Older drivers are especially bothered by glare from the lights of other vehicles.

- ▶ **Use your high beams when it is safe and legal.** High beams increase your ability to see. However, glare from your headlights can blind other drivers. Dim your lights within 500 feet of an oncoming vehicle. Dim your light when following within 200 feet of another vehicle. If a driver coming toward you doesn't dim his lights, don't get back by turning on your high beams. This increases the chance of a crash.
- ▶ **Don't look directly at bright lights when driving.** Look to the right of the road. Watch the side of the road when another car or truck comes toward you. It can take several seconds to recover from blindness caused by glare. Even two seconds of glare blindness can be dangerous. A vehicle going 55 mph will travel more than half the distance of a football field during that time.
- ▶ **Get enough sleep before you drive.** Being tired and lack of alertness are problems for drivers at night. Most people are less alert at night, especially after midnight. This is even more true if you have been driving for a long time.

- ▶ **If you are sleepy, pull off the road and get some sleep.** You cannot control your need for sleep. Drivers who are tired may not see hazards as soon or react as quickly. This increases the chance of a crash.

**The roadway:** During the day, there is usually enough light to see well. At night, some streets may have bright lights, but others will have poor lighting. On most roads, you will probably have to depend on your headlights.

Less light means you will not be able to see hazards as quickly. Pedestrians, joggers, bicyclists, animals and other objects may be difficult to see. Even when there are street lights; the scene may be confusing. Traffic signals and hazards can be hard to see against a background of signs, store windows and other lights.

- ▶ **Drive slower when lighting is poor or confusing.** Drive slowly enough so that you can stop within the distance that you can see ahead.
- ▶ **Watch for drunk drivers.** Be extra careful when bars and restaurants are closing. Watch drivers who weave, drive too slow or too fast, or stop for no reason.

**The vehicle:** At night, you must depend on your headlights to see and be seen. However, you can't see as much with your headlights at night as you can see during the day.

- ▶ **Adjust your speed so that you can stop within the distance that you can see ahead.** With your low beams, you can see ahead about 250 feet. With your high beam, you can see ahead between 300 and 500 feet. If you are driving with your low beams on, you should be able to stop within 250 feet. If you are driving with your high beams on, you should be able to stop within 300 to 500 feet.

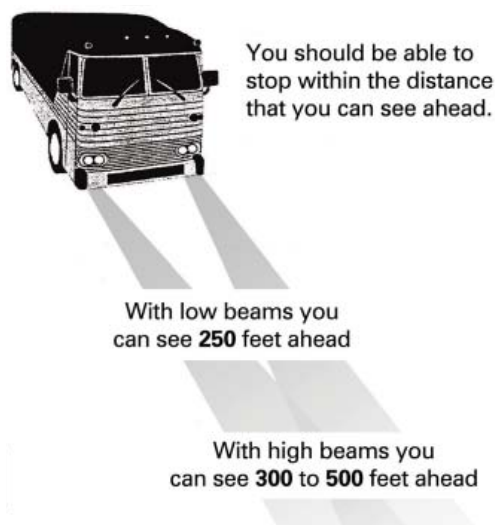

- ▶ **Make sure that your headlights are clean and adjusted properly.** Dirty headlights give only half the light they should. This makes it harder for you to see and harder for other drivers to see you. If your headlights are out of adjustment, they won't give you a good view and they can blind other drivers.

- ▶ **Be sure that all lights and reflectors are clean and working so that other drivers can see you.** These lights include:
  - ▶ Markers lights
  - ▶ Clearance lights
  - ▶ Tail lights
  - ▶ Identification lights
  - ▶ Turn signals
  - ▶ Brake lights
- ▶ **Be sure that your windshield and mirrors are clean.** Dirt on your windshield and mirrors can increase the glare from other vehicles' lights. This will make it hard for you to see other vehicles and hazards.

## Fog

Fog reflects light and can reflect your own headlights back into your eyes. Use only your low beams. Look for road edge markings to guide you. Even light fog reduces your ability to see and judge distances. If possible, pull off the road and wait until the fog has lifted. If you must drive, be sure to:

- ▶ Obey all fog-related warning signs
- ▶ Reduce your speed
- ▶ Turn on all your lights
- ▶ Use only your low beams
- ▶ Be prepared for sudden stops

## Cold Weather Driving

### Vehicle Checks

During your pre-trip inspection, pay extra attention to the following items. Be sure that these systems are working correctly and that you know how to use them before you begin driving.

- ▶ Coolant and antifreeze
- ▶ Defrosting and heating equipment
- ▶ Wipers and washers
- ▶ Tires (Be sure your tires have enough tread to provide sufficient traction to steer and push the vehicle through snow).

In addition:

- ▶ **Clear your vehicle of all snow and ice.** Be sure your lights, reflectors, windows and mirrors, handholds, steps and deck plates are free of snow and ice.
- ▶ **As a precaution, carry the right number of chains and extra cross links.** Make sure they fit your drive tires. Check the chains for broken hooks, worn or broken cross links and bent or broken side chains. Learn how to put the chains on before you need to use them.

- ▶ **Remove ice from the radiator shutters.** Make sure the winterfront is not closed too tightly. If the shutters freeze or the winterfront is closed too much, the engine may overheat.
- ▶ **Check the exhaust system for loose parts and for signs of leaks.** Loose connections can let carbon monoxide leak into the vehicle. This can cause sleepiness. In large amounts it can kill you.

### Driving Tips

- ▶ **Drive smoothly and slowly on slippery roads.** Don't hurry. If the roads are very slippery, don't drive at all. Stop at the first safe place.
- ▶ **Adjust turning and braking to road conditions.** Make turns as gently as possible. Don't brake any harder than necessary. Don't use the engine brake or speed retarder on slippery or wet roads. They can cause the driving wheels to skid.
- ▶ **Adjust speed to conditions.** Don't pass slower vehicles unless necessary. Go slow and watch far enough ahead to keep a steady speed. Avoid slowing down and speeding up. Take curves at slower speeds and don't brake while you're in the curve.

Remember, as the temperature rises and the ice begins to melt, the road becomes even more slippery.

- ▶ **Adjust space to road conditions.** Don't drive beside other vehicles. Keep extra following distance. Watch ahead for slowing or stopped traffic. Slow down gradually.
- ▶ **Avoid driving through deep puddles or flowing water.** Water in your brakes can cause the brakes to be weak, apply unevenly or to grab. This reduces braking power and causes wheel lockups and pulling to one side. It could cause a jackknife if you are pulling a trailer. If you must drive through water, following these steps:
  - ▶ Slow down.
  - ▶ Put your transmission in low gear. Engage the clutch smoothly.
  - ▶ Put on the brakes gently. This presses the linings against the brake drums or discs and keeps mud, silt, sand and water out of your brakes.
  - ▶ Increase the engine RPM and cross the water while keeping light pressure on your brakes.
  - ▶ As soon as you are out of the water, maintain light pressure on the brakes for a short distance. This will heat them and dry them out.
  - ▶ Make a test stop as soon as it is safe. If the brakes do not work well, drive for another short distance with light pressure on the brakes. Don't apply too much pressure on the brakes or you may overheat the brake drums and linings.

### Hot Weather Driving

#### Vehicle Checks

- ▶ **Make sure you have plenty of engine oil and engine coolant.** Engine oil lubricates the engine and helps keep it cool. Antifreeze helps the engine under hot conditions and in cold conditions. While you are driving, check the oil temperature gauge and the engine temperature gauge. If these gauges show a temperature higher than normal, stop driving as soon as safely possible. There could be something wrong that could lead to engine failure or fire.
- ▶ **Check engine belts and hoses.** Check the belts for tightness by pressing on the belts. Be sure coolant hoses are in good condition. Loose belts or broken hoses can lead to engine failure and fire.
- ▶ **While you're driving, inspect the tires every two hours or every 100 miles.** Air pressure increases with temperature. Do not let air out. If you let air out, the pressure will be too low when the tires cool. If a tire is too hot to touch, remain stopped until the tire cools. Otherwise, the tire may blow out or catch on fire.
- ▶ **Never remove the radiator cap or any part of the pressurized system until the system has cooled.** Steam and boiling water can spray under pressure and cause severe burns. If you can touch the radiator cap with your bare hand, it is probably cool enough to open. You can also check the coolant level of a hot engine if a coolant container is part of a pressurized system.

#### Driving Tips

- ▶ **Watch for bleeding tar.** In hot weather, spots where tar bleeds to the road surface are very slippery.
- ▶ **Drive slow enough to prevent overheating.** High speeds create more heat for tires and the engine. In desert conditions, the heat may rise to a dangerous level. The heat will increase the chance of tire failure, engine failure and fire.

### Mountain Driving

Gravity plays a major role in mountain driving. On upgrades, gravity slows you down. The steeper and longer the grade, and the heavier your load, the slower you will drive. When coming down a downgrade, gravity increases the speed of your vehicle. Try to plan ahead and get information about any steep grades along your planned route.

- ▶ **Select a safe speed.** Base your speed on the following:
  - ▶ The weight of your vehicle and cargo
  - ▶ Length of the grade
  - ▶ Steepness of the grade
  - ▶ Road conditions
  - ▶ Weather conditions

- ▶ **Never drive faster than the speed posted on “Maximum Safe Speed” signs.** Remember that the speed posted on these signs could be too fast for a large vehicle or for the weather conditions.
- ▶ **Pay attention to warning signs that tell the length and steepness of the grade.**
- ▶ **Use the braking effect of your engine to maintain a safe speed.** The braking effect of the engine is best when the transmission is in a low gear. Save your brakes so you can slow down or stop for traffic and road conditions.
- ▶ **Shift the transmission to a lower gear before you start down the grade.** Don't downshift after you've gained speed. You won't be able to shift into a lower gear. You may not be able to get back into any gear. For older trucks, use the same gear for going down a hill that you would use to climb the hill. New trucks have more powerful engines and can climb hills in higher gears than older trucks. Therefore in newer trucks, use a lower gear for going down a hill than you would use for climbing the hill.
- ▶ **Be sure your brakes are adjusted before you begin a trip through the mountains.** If you use your brakes too much, they will fade. Excessive heat causes the brake drums to expand. As a result, the brake shoes have to travel further and exert less stopping force. This situation is made even worse if the brakes were not properly adjusted to begin with. Remember, the more you use your brakes, the more quickly they will get out of adjustment.
- ▶ **Use the proper braking technique.** Use your brakes on a long, steep downgrade plus the braking power of your engine. When your vehicle is in the proper low gear, use this braking technique:
  - ▶ Apply the brakes just enough to feel a definite slowdown.
  - ▶ Reduce your speed to 5 mph below your safe speed. This should take about 3 seconds. Then, release the brakes.
  - ▶ When your speed has increased to your safe speed, repeat the first steps.
- ▶ **Know where the escape ramps are located on your route.** Escape ramps have been built on many steep downgrades. They are made to stop runaway vehicles without injuring drivers and passengers. Escape ramps use a long bed of loose soft material to slow runaway vehicles. **Use them if you lose your brakes.**

If your safe speed on a steep grade is 40 mph, don't apply your brakes until your speed reaches 40 mph. Apply your brakes enough to reduce your speed to 35 mph. This should take about 3 seconds. Release the brakes. Repeat these steps until you reach the end of the downgrade.

### Railroad Crossing

Railroad crossings are always dangerous. Always look both ways. Trains may come at any time from either direction. Follow these rules when crossing railroad tracks.



- ▶ Don't try to race a train to the crossing. It is very difficult to judge the speed of a train.
- ▶ Reduce your speed. Be sure you can stop before you reach the tracks if necessary.
- ▶ Because of the noise in your cab, you won't hear the train horn until the train is very close.
- ▶ Don't rely on train warning signals or flagmen to let you know of an approaching train.
- ▶ Double tracks require more caution. A train on one track may hide a train on the other track.
- ▶ After one train has cleared the crossing, check again. Be sure that no other train is coming before you cross the tracks.
- ▶ A railroad crossing with steep approaches can cause your vehicle to hang up on the tracks. This is most likely to happen to vehicles that have low ground clearance, such as drop frame trailers and car carriers. If you get hung up on a railroad crossing, notify the police immediately so that nearby trains can be stopped.
- ▶ Be sure you can get all the way across the tracks before you begin to cross.
- ▶ Do not shift gears when crossing railroad tracks.
- ▶ Vehicles equipped to carry passengers or hazardous cargo must come to a complete stop at railroad crossings. You **must** also stop if the lights are flashing, the arms are down or you are directed to stop by signs or the police.

- ▶ **Find an escape route.** While slowing your vehicle, look for an escape route—an open field, side street or escape ramp.

### Air Brake Fading or Failure

Excessive use of the service brakes causes overheating and leads to brake fade. Excessive heat in the brakes causes chemical changes in the lining which reduce friction and cause the brake drums to expand. As the overheated drums expand, the brake shoes and linings have to move farther to contact the drums. The force of contact between the shoes and drums is also reduced. Overuse may increase brake fade until the vehicle cannot be slowed or stopped at all.

Brakes that are out of adjustment may also cause brake fade. To safely control the vehicle, every brake must do its share of the work. Brakes out of adjustment stop doing their share before brakes that are in adjustment. This causes the other brakes to overheat and fade. Brakes can get out of adjustment quickly, especially when they are hot. Therefore, brake adjustment must be checked frequently.

**Brake failure on downgrades.** Driving slowly and braking properly will almost always prevent brake fade on long downgrades. Once the brakes fail, however, you must look outside your vehicle for something to stop it.

Your best hope is an escape ramp. Ramps are usually located a few miles from the top of a downgrade. Signs will be posted telling you about it. Use the escape ramp if it is available.

If you don't see an escape ramp, take the least hazardous escape route—an open field or a side road that flattens out or turns up hill.

Look for an escape route as soon as you know that your brakes don't work. The longer you wait, the more speed your vehicle will gain and it will be harder to stop.

## Equipment Failures

### Brake Failures

Brakes kept in good condition seldom fail. Most hydraulic brake failures occur for two reasons: 1) loss of hydraulic pressure or 2) brake fade on long hills.

**Loss of hydraulic pressure.** When the system won't build up pressure, the brake pedal will feel spongy or go to the floor. Take the following steps:

- ▶ **Downshift.** Putting your vehicle in a lower gear will help slow the vehicle.
- ▶ **Pump the brakes.** This will sometimes generate enough hydraulic pressure to stop the vehicle.

### Tire Failure

The sooner that you know a tire has failed the more time you will have to react. The major signs of a tire failure are:

- ▶ **Sound.** A loud bang often indicates a blowout. However, it may take several seconds for your vehicle to react and you might think that the sound came from another vehicle. Any time you hear a tire blow, assume that it was one of your tires.
- ▶ **Vibration.** If your vehicle thumps or vibrates, a tire may have gone flat. With a rear tire, this may be the only sign you get.
- ▶ **Feel.** If the steering feels heavy, one of the front tires has probably failed. Sometimes, failure of a rear tire causes the vehicle to slide back and forth or fishtail. However, dual rear tires usually prevent this.

## Section 1: General Knowledge

If a tire fails, take the following steps:

- ▶ **Hold the steering wheel firmly.** If a front tire fails, it can twist the steering wheel out of your hand. Keep a firm grip on the steering wheel with both hands at all times.
- ▶ **Stay off the brakes.** Braking when a tire has failed could cause you to lose control. Unless you are about to run into something, stay off the brake until the vehicle has slowed down. Then, brake gently and pull off the road.
- ▶ **Check the tires.** Even if the vehicle seems to be handling normally. Many times you won't know that a dual tire is flat unless you look at it.

### Crashes

If you are in a crash and not seriously hurt, you need to take three steps to prevent further damage or injury:

- ▶ Protect the area.
- ▶ Notify the authorities.
- ▶ Care for the injured.

### Protect the Area

To prevent another crash this is the first thing you should do.

- ▶ If your vehicle is involved in the crash, try to move it to the side of the road. This will help prevent another crash.
- ▶ If you are stopping to help at the scene of a crash, park away from the crash. The area around the crash will be needed by emergency vehicles.
- ▶ Put on your flashers.
- ▶ Set out reflective triangles to warn other traffic. Make sure that other drivers will see them in time to avoid another crash

### Notify the Authorities

If you have a CB or cellular telephone, put out a call over the emergency channel or dial 911 before you get out of your vehicle. If not, wait until the crash scene has been protected, then phone or send someone to phone the police. Remember to determine where you are so you can give an accurate location.

### Care for the Injured

If a qualified person is helping the injured, stay out of the way unless asked to assist. Otherwise, do the best you can to help anyone who is injured.

- ▶ Don't move a severely injured person unless there is a danger of fire or passing traffic makes it necessary.
- ▶ Stop heavy bleeding by applying direct pressure to the wound.
- ▶ Keep the injured person warm.

## Fires

Truck fires can cause damage and injury. Learn the causes of fires and how to prevent them. Know what to do to extinguish fires.

### Causes of Fire

- ▶ **After accidents:** spilled fuel, improper use of flares
- ▶ **Tire:** under-inflated tires and dual tires that touch
- ▶ **Electrical system:** short circuits due to damaged insulation, loose connections
- ▶ **Fuel:** driver smoking, improper fueling, loose fuel connections
- ▶ **Cargo:** flammable cargo, improperly sealed or loaded cargo, poor ventilation

### Fire Prevention

- ▶ **Pre-trip inspection:** Make a complete inspection of the electrical, fuel and exhaust systems, tires and cargo. Be sure that your fire extinguisher is charged. Be sure that you know how to use it.
- ▶ **Inspections while traveling:** Check the tires and hubs for signs of excessive heat whenever you stop during a trip. Frequently check the instruments and gauges for signs of overheating. Use your mirrors to look for signs of smoke from the tires or other areas of the vehicle.
- ▶ **Safe procedures:** Don't get careless. Always follow correct safety procedures for fueling the vehicle, using brakes, handling flares and other activities that can cause a fire.

### Fire Fighting

Your life and the lives of others may depend on your ability to fight a fire. Study the instructions printed on the extinguisher. Know how your fire extinguisher works before you drive the vehicle. If a fire occurs:

- ▶ **Pull off the road.**
  - ▶ Park in an open area away from buildings, trees, brush, other vehicles or anything that might catch fire.
  - ▶ **Don't pull into a service station.**
  - ▶ Notify the police of your problem and location.
- ▶ **Keep the fire from spreading** before you try to put it out.
  - ▶ **If your engine is on fire,** turn off the engine as soon as you can. Open the hood as little as possible. Shoot the fire extinguisher through louvers, the radiator grille or from the underside of the vehicle.

- ▶ **If you have a cargo fire in a van or box trailer**, keep the doors shut, especially if your cargo contains hazardous materials. Opening the doors will supply the fire with oxygen and will cause it to burn very fast.
- ▶ Use the right fire extinguisher: By regulation, B:C extinguishers are required on commercial vehicles, A:B:C are an acceptable alternate.
  - ▶ **B:C type extinguishers** work on electrical fires and burning liquids. Don't use water on electrical or gasoline fires.
  - ▶ **A:B:C type extinguishers** work on burning wood, paper and cloth as well as burning liquid and electrical fires.
  - ▶ **Water** can be used on wood, paper, cloth and burning tires. Don't use water on an electrical fire (you could get shocked) or on a fire involving petroleum products.
- ▶ If you're not sure what to use, especially if you have a hazardous material fire, wait for qualified fire fighters.
- ▶ **Extinguish the fire** only if you know what you are doing and it is safe to do so.
  - ▶ When using the extinguisher, stay as far away from the fire as possible.
  - ▶ Aim at the source or base of the fire, not up in the flames.
  - ▶ Position yourself upwind. Let the wind carry the extinguisher to the fire instead of carrying the flames to you.
  - ▶ Be sure you have a path of retreat if you are unable to control the fire.
  - ▶ Continue until whatever was burning has cooled. If you don't see any smoke or flames, don't assume that the fire is out. It could be smoldering and it could restart.

## Hazardous Materials Rules for All Commercial Drivers

All drivers should know something about hazardous materials. You must be able to recognize hazardous materials and you

must know if you can haul it without having a hazardous materials endorsement on your commercial driver's license.

*Hazardous materials are products that pose a risk to health, safety and property during transportation.* The table below lists 9 hazard classes.

Class	Division	Name of Class or Division	Example
1	1.1	Explosives (Mass Detonation)	Dinitrophenol
	1.2	Projections Hazards	Ammunition Smoke, White Phosphorus
	1.3	Mass Fire Hazards	Article, Explosive No. 5
	1.4	Minor Hazards	Fireworks
	1.5	Very Insensitive	Blasting Agents Explosive, Blasting, Type E
	1.6	Extremely Insensitive	Article, Explosive Extremely Insensitive
2	2.1	Flammable Gases	Propane
	2.2	Non Flammable Gases	Helium, Compressed
	2.3	Poisonous/Toxic Gases	Fluorine, Compressed
3		Flammable Liquids	Gasoline, Alcohol, Diesel Fuel, Fuel Oils
4	4.1	Flammable Solids	Ammonium Picrate, Wetted
	4.2	Spontaneously Combustible	Phosphorus, White Dry
	4.3	Dangerous When Wet	Sodium
5	5.1	Oxidizers	Ammonium Nitrate, Liquid
	5.2	Organic Peroxides	Organic Peroxide Type, B Liquid
6	6.1	Poison (Toxic Material)	Potassium Cyanide
	6.2	Infectious Substances	Diagnostic Specimen
7		Radioactive	Radioactive Material, Uranium Hexafluoride
8		Corrosives	Sulfuric Acid
9		Miscellaneous Hazardous Materials	Airbag Inflators, Asbestos
None		ORM-D (Other Regulated Material-Domestic)	Consumer Commodity
Combustible Liquid		Combustible Liquid	Diesel Fuel, Fuel Oil

You must follow the rules for transporting hazardous materials. These rules ensure safe drivers and equipment. They also tell you how to contain a hazardous material and how to communicate its risk.

## Section 1: General Knowledge

### To Ensure Safe Drivers and Equipment

Definition: Placards are diamond-shaped signs put on the outside of a vehicle to warn others. They identify the hazard class of the cargo.

Drivers of placarded vehicles must have a commercial driver's license with the hazardous materials endorsement. Drivers must learn how to safely load and transport hazardous materials.

To get the endorsement, you must pass a written test on Section 9 of this manual. If you transport hazardous materials in a cargo tank with a gross vehicle weight rating of 26,000 pounds or more, you will also need a tank vehicle endorsement, Section 7.

**Never drive a vehicle that needs placards unless you have a hazardous materials endorsement.** Transporting hazardous materials without the proper placards is a crime. You will be stopped, cited and you will not be allowed to drive your truck further. It will cost you time and money.

Driving without the proper placards could also risk your life and the lives of others. If you have a crash, emergency workers will not know about your hazardous cargo.

Hazardous materials drivers must also know which products they can load together. Section 9 of this manual covers these regulations. Before loading a truck with more than one type of product, you must know if it is safe. If you do not know, ask your employer.

### To Contain a Hazardous Material

Many hazardous materials can injure or kill on contact. Federal regulations tell shippers how to package these materials safely. This protects drivers and others from contact with the hazardous materials. Other regulations tell drivers how to load, transport and unload bulk tanks. These are called containment rules.

### To Communicate the Risk

The shipper uses a shipping paper, package labels and placards to warn dock workers and drivers of the presence of hazardous materials, the hazard class and the specific hazardous material.

**The shipping paper** describes the hazardous material being transported. Shipping orders, bills of lading and manifests are examples of shipping papers.

After an accident or hazardous material spill or leak, you may be injured and unable to tell others about your hazardous cargo. Fire fighters and police can prevent or reduce the amount of damage and injury if they know what hazardous materials you are carrying. Your life and the lives of others

could depend on quickly locating hazardous materials shipping papers. For this reason, you must tab shipping papers related to hazardous materials or keep them on top of other shipping papers.

You must keep shipping papers:

- ▶ In a pouch on the driver's door, or
- ▶ In clear view and within reach while driving, or
- ▶ On the driver's seat when you are out of the vehicle.

**Shipping labels** are four-inch, diamond-shaped warning labels and are placed on hazardous materials packages. These labels inform others of the hazard. If the diamond label won't fit on the container, shippers put the label on a tag. For example, compressed gas cylinders that will not hold a label will have tags or decals.

**Placards** are 10 <sup>3</sup>/<sub>4</sub> inches on each side and are diamond-shaped. Cargo tanks and other bulk packaging display the I.D. number of their contents on placards or orange panels. A placarded vehicle must have at least 4 identical placards. They are placed on the front, rear and both sides of the vehicle.

Not all vehicles that carry hazardous materials need placards. The regulations about placards are given in Section 9 of this manual. You can drive a vehicle carrying hazardous materials if it does not require placards. If it requires placards, you may not drive it unless you have a hazardous material endorsement on your commercial driver's license.

## Staying Alert and Fit to Drive

Driving a commercial vehicle requires skill, education and physical fitness. Driving for long hours is tiring and even the best drivers will become less alert. You can cope with fatigue and maximize your alertness by following the federal regulations on hours of service and off duty time. You can also combat fatigue and maximize your alertness by maintaining a healthy lifestyle.

### Federal Regulations on Hours of Service and Off-Duty Time

In an effort to control driver fatigue, the federal government established regulations governing hours of service and required off-duty time. These regulations specify driving time, off-duty time and prohibit driving after you have been on-duty in excess of specified amounts of time. Refer to the Federal Motor Carrier Safety Regulations for specific requirements.

### Staying Alert

- ▶ **Get enough rest.** When you go off duty, your first concern should be to get enough rest so that you will

have the 7 to 8 hours sleep that every person needs. After you have gotten your sleep and you have been awake and alert for more than 8 hours without being notified of your next assignment, take a short nap so you will be alert when you return to work. Remember, sleep is the only way to overcome fatigue.

- ▶ **Schedule your trips safely.** Ideally, you should try to schedule trips for the hours when you are normally awake. However, many motor carriers operate around the clock. Therefore, you must be prepared to drive safely during irregular work times.
- ▶ **Rest during your off-duty times.** Everyone is affected by the circadian rhythm. This is the name of the 24-hour cycle of alertness and sleep that affects everyone. Normally, most people have low points of alertness from 2 to 6 a.m. and from 2 to 5 p.m. If you are already tired, your risk of falling asleep during these periods is greatly increased. That's why it's important to get as much rest as possible during your off-duty hours. Remember, many heavy vehicle crashes occur between midnight and 6 a.m.
- ▶ **Take a nap.** If you get sleepy, a short nap will do more for you than a cup of coffee. Find a safe place to pull over and stop. Remember, parking on the shoulder of an interstate or other main highway is dangerous and is not permitted except in an emergency. Napping is not considered an emergency. Find a rest area, truck stop or a safe place along a nearby road.
- ▶ **Avoid drugs.** No drugs can help you overcome being tired. Stimulants may keep you awake for a while; but, they won't make you alert. When they wear off, you'll be even more tired than if you had never taken them. Sleep is the only way to overcome fatigue.
- ▶ **Avoid medication.** Many medications can make you sleepy. These medications usually have a label or folder that warns against operating vehicles or machinery while taking them. Cold pills are one of the most common medicines that will make you sleepy. If you must drive with a cold, you are better off suffering from the cold than from the effects of the medicine.
- ▶ **Keep cool.** A hot, poorly ventilated cab can make you sleepy. Keep the window or vent cracked, or use the air conditioner.
- ▶ **Take a break.** Stay alert by stopping for a short break every 2 to 3 hours. Walk around and give your vehicle a safety check.

## Drinking and Driving

Every year, roughly 19,000 people are killed because of drivers who have been drinking. About one-half of all fatal crashes involve drinking drivers. Be sure that you know the facts.

False	True
A few drinks will improve your driving.	Alcohol is a drug that will make you less alert and reduce your ability to drive safely.
Some people can drink a lot and not feel the effects.	Everyone who drinks alcohol is affected. Just one drink affects your ability to drive safely.
If you eat a lot, you won't get as drunk.	Food will not keep you from getting drunk.
Coffee and fresh air will help you get sober.	Only time will help you get sober. Other methods don't work.
Stick with beer. It's not as strong as wine or whiskey.	A 12-ounce glass of beer, a five-ounce glass of wine and a shot of liquor have the same amount of alcohol.

### Just one alcoholic drink can affect your driving ability.

Even a small amount of alcohol affects the brain. Alcohol first affects the part of the brain that controls judgment and self-control. This can keep you from knowing when you are getting drunk. Alcohol affects your judgment and driving ability. Your chances of being in a crash are seven times greater if you drive after drinking than if you drive sober.

### Alcohol also affects coordination, reaction time and vision.

Ninety percent of the information used in driving comes from seeing. Alcohol relaxes the eye muscles. As a result, you cannot focus properly. Any restriction in vision could cause you to crash.

**Blood alcohol content (BAC)** is the amount of alcohol in your body. BAC depends on the amount of alcohol consumed, the time spent drinking and your body weight. The more you drink, the higher your BAC will be and the more affected your driving will become.

**It takes at least an hour** for the blood stream to rid itself of one ounce of alcohol. Only time can get rid of the effects of alcohol. Coffee, cold showers or exercise will not make you sober.

**Mixing alcohol with other drugs usually multiplies the effects of both.** Having one drink and taking an aspirin or simple cold pill could have the same effect as several drinks.

### Almost any drug can reduce your ability to drive safely.

It's not just illegal drugs that cause problems. Many over-the-counter drugs and prescription drugs can cause sleepiness and dizziness. These drugs often affect your alertness and reaction time.

**Read the label before taking any drug or medicine.** Look for warnings about the side effects. If you are uncertain about the effects of a drug, ask your doctor or pharmacist.

## Section 1: General Knowledge

**Laws prohibit possession and use of many drugs while you are on duty.** It's illegal to be under the influence of any controlled substance, narcotic or other substance that can make a driver unsafe. This includes prescription and over-the-counter drugs that may make you sleepy or affect your driving ability. Possession and use of a drug is legal if your doctor tells you that the drug will not affect your driving ability.

### Alcohol and Drug Testing

Federal regulations require that drivers who operate a commercial motor vehicle and hold a CDL, be tested for misuse of alcohol and the use of controlled substances such as amphetamines, marijuana, opiates, PCP and cocaine.

- ▶ **Testing for misuse of alcohol:**
  - ▶ on a random basis;
  - ▶ for a reasonable suspicion of misuse;
  - ▶ following a crash, and
  - ▶ when returning to duty.
- ▶ **You may be tested for controlled substances:**
  - ▶ prior to employment;
  - ▶ on a random basis;
  - ▶ for reasonable suspicion of use;
  - ▶ following a crash, and
  - ▶ when returning to duty.

Promptly follow your employer's instructions for alcohol and drug testing.

Violation of the regulations for alcohol and drug use and testing can jeopardize your career as a commercial driver.

## Section 2: Air Brakes



**If you plan** to drive a truck or bus with air brakes, you need to study this section. If you plan to pull a trailer with air brakes, you must study this section and Section 3: Combination Vehicles.

Air brakes use **compressed air** to make the brakes work. Air brakes stop large and heavy vehicles safely; but the brakes must be maintained and used correctly.

Air brakes are three different braking systems: service brake, parking brake and emergency brake systems.

- ▶ The **service brake system** applies and releases the brakes when you use the brake pedal during normal driving.
- ▶ The **parking brake system** applies and releases the parking brakes when you use the parking brake control.
- ▶ The **emergency brake system** uses parts of the service and parking brake systems to stop the vehicle if the service brake system fails.

### Air Brake System Parts

- ▶ **Air compressor** pumps air into the air storage tanks (reservoirs). It is connected to the engine through gears or a v-belt. The compressor may be air cooled or cooled by the engine cooling system. It may have its own oil supply or it may be lubricated by engine oil. If the compressor has its own oil supply, check the oil level during the pre-trip inspection.
- ▶ **Air compressor governor** controls when the air compressor pumps air into the air storage tanks. When air tank pressure rises to the cut-out level (around 125 pounds per square inch—psi), the governor stops the